

MOBILE LIFTER

ML-120



POWERFUL

ERGONOMIC

PRACTICAL

VERSATILE

ECONOMIC

LIFTING TABLES & WORK BENCHES
HANDLING & LIFTING EQUIPMENT
GLUING PRESSES
UNDER-TABLE CROSSCUT SAWS
ROLLER & MEASURING CONVEYORS

MOBILE LIFTER

ML-120



LOAD CAPACITY
max. 120 kg



PANEL SIZES
up to 2.100 x 3.200 mm



TOTAL HEIGHT
2.090 mm

THE PERFORMANCE PARTNER FOR LARGE-FORMAT PLATES

With the Mobile Lifter from Reinhold Beck Maschinenbau GmbH, handling large-format panels in your upright panel store will no longer be a problem in the future. Equipped with six gentle yet strong suction pads, a load capacity of up to 120 kg can be guaranteed. Panels with a size of 2,100 x 3,200 mm can be transported easily. An extra-sturdy hose, which serves as a vacuum tank, maintains the vacuum even when the powerful vacuum pump is switched off. This way, the vacuum can always be maintained and accidents or transport damage can be ruled out. In the future, you and your team can work ergonomically without using your own physical strength.

Stacking of pallet heights up to 1,600 mm, electrically operated	
Tilt angle forward-backward 180°, electrically operated	
Head joint rotation angle clockwise/counterclockwise	180°
Head joint rotation angle	360°

The Mobile Lifter ML-120 consists of:

- + a mobile base
- + an electric lifting and tilting system
- + an automatic vacuum unit
- + a wireless, electric control system

Weight	170 kg
--------	--------

ART.: 350.100.00



FOOT



BATTERY



ELECTRICAL

THE PRACTICAL ASSISTANT FOR:

- + Rotate large-format panels from the vertical to the horizontal
- + Feeding large format panels to the processing machine
- + Transport of large-sized panels from the warehouse to the production hall
- + The feeding of large format panels into a panel saw

BATTERY CHARGING SYSTEM

The rechargeable battery system has two powerful rechargeable battery cells, which are easily charged via plug-in system.



RADIO REMOTE CONTROL

The Mobile Lifter can be flexibly controlled with the intuitive radio remote control.



VARIABLY HEIGHT ADJUSTABLE UNDER LOAD

SUCTION PADS ARE ADJUSTABLE IN WIDTH

360° ROTATABLE

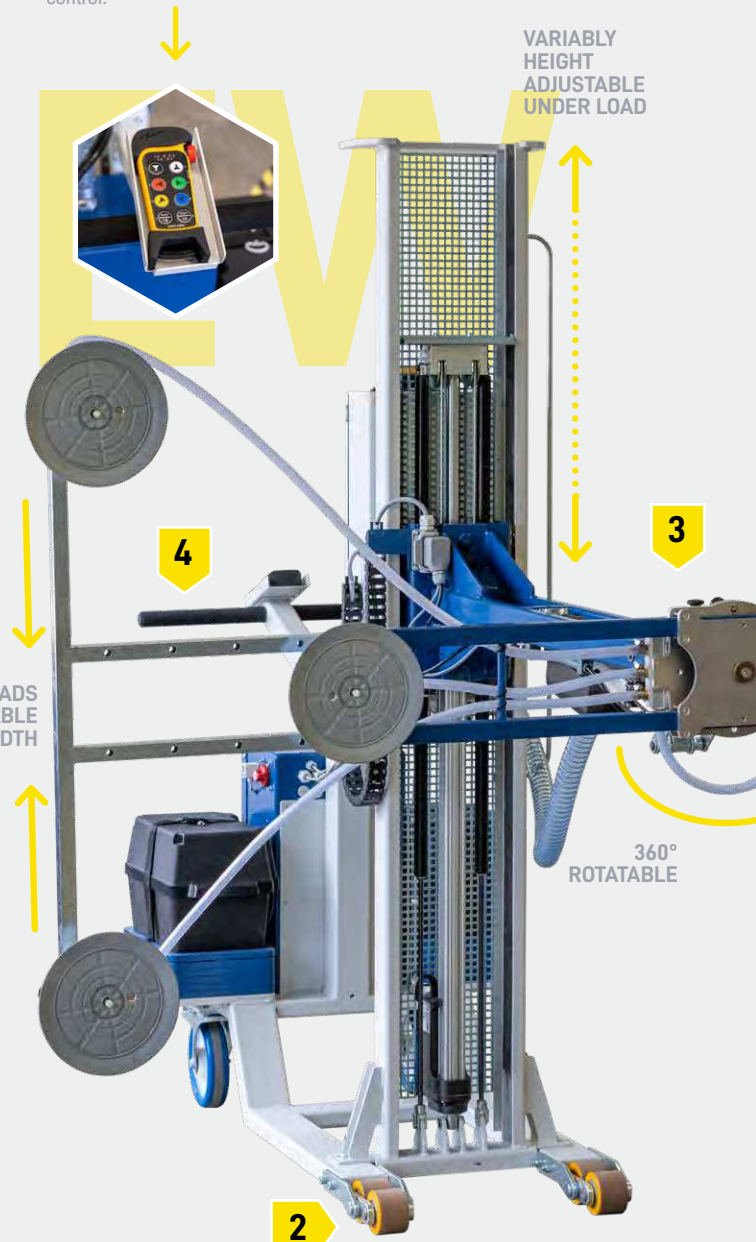

MOBILE



Scan QR code and watch user video:
<https://www.youtube.com/watch?v=YtNK5B50Zxg>

SAFE STAND

Thanks to counterweights, a secure stand is guaranteed in every situation.

HIGHLIGHT

THIS IS WHAT MAKES THE TEAMER MOBILE LIFTER SPECIAL:

1



Six powerful suction pads with sensing valve for panel transport.

2



The compact design allows the Mobile Lifter to be moved as close as possible to the machines.

3



The head joint can be rotated 360° and is therefore flexibly adjustable.

4



The Mobile Lifter can be flexibly moved to the desired position by means of the handlebar.

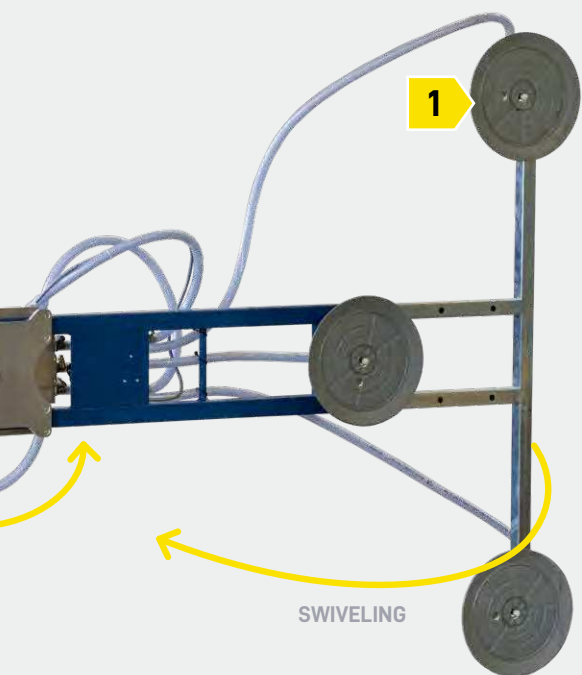
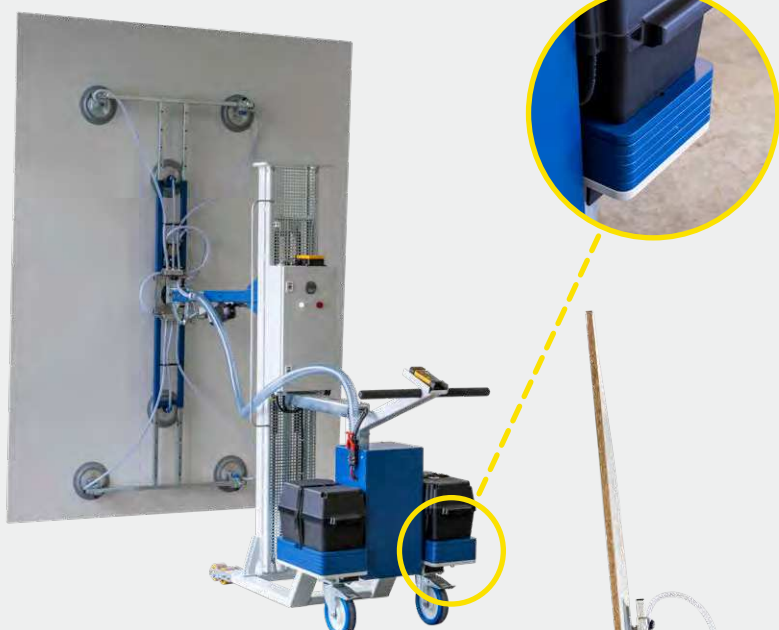

SWIVELING

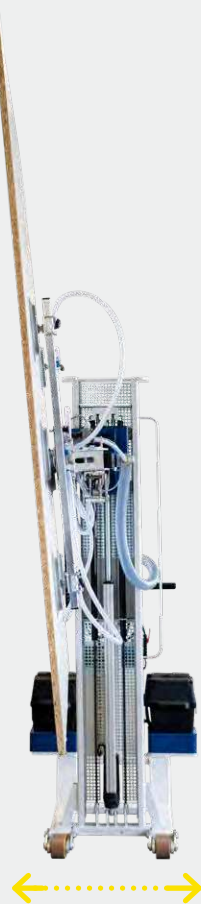

PARTICULARLY NARROW

The 180° swivelling head joint enables panel handling in the tightest of spaces.

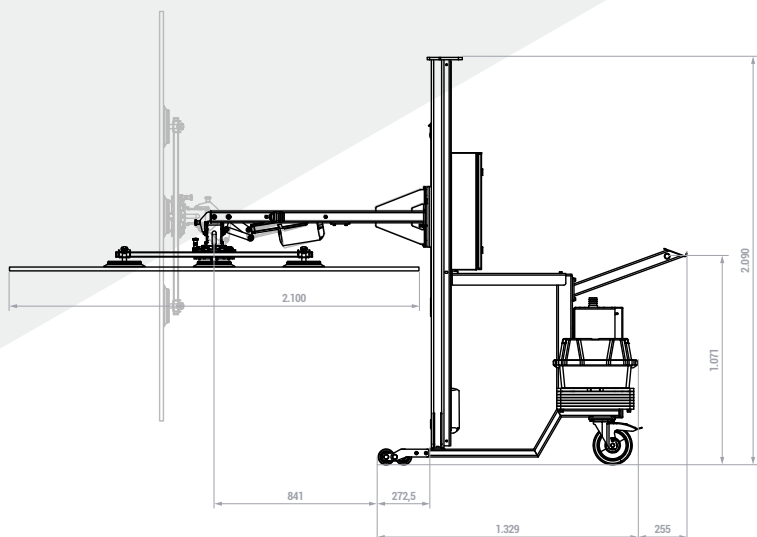

FOLLOW US

   @beck_maschinenbau



SHOWROOM
TRY IT OUT,
EXPERIENCE IT,
FALL IN LOVE ...

Our showroom in Sigmaringen (Southern Germany) is a year-round product presentation and is used to try out products and machines. Visit us!

Reinhold Beck Maschinenbau GmbH
Im Grund 23 | 72505 Krauchenwies
GERMANY
Tel. +49 7576 962978-0
info@beck-maschinenbau.de
www.beck-maschinenbau.com

 AVAILABLE IN THE SHOP: www.hokubema.com

HOKUBEMA
Maschinenbau GmbH

PANHANS
QUALITÄT SEIT 1918

SIITEC
SCHNEIDTECHNIK



MADE IN GERMANY

Subject to technical and optical changes.
No liability for printing errors and altered images.