

# SUPPORTER

## AM 500-FLEXX + AM 1200-FLEXX | FH



**PAYLOAD**  
AM 500: up to 500 kg  
AM 1200: up to 1,200 kg



**PLATFORM SIZE**  
2,000 x 1,000 mm



**OVERALL HEIGHT**  
max. 1,070 mm

Our continuously height-adjustable supporters in the sizes AM 500-Flexx and AM 1200-Flexx are more than work and assembly tables. Well thought-out functions have been taken from practice and further developed in such a way that the ideal partner for every workshop is created. The AM 500-Flexx has a lifting unit in the left and the AM 1200-Flexx has two lifting units, which are concealed in the left and right lifting columns in order to be protected from dirt and damage.

# NEW

Useful stroke	300 mm
Construction height of the supporter	770 mm
Weight*	
AM 500	approx. 150 kg
AM 1200	approx. 180 kg
* For accessories, please pay attention to the weight of the support plate and the permissible load of the supporter	
Space below the worktop	
Including bottom shelf	
5 laterally adjustable C-profile support rails with hardwood supports (Hardwood supports are adjustable in depth in the C-profile rail)	
Standard without worktop	
4 swivel castors (wheel ø 125 mm), 2 of which have brakes	

AM 500-FLEXX: ART.: 210.130.00  
AM 1200-FLEXX: ART.: 210.140.00

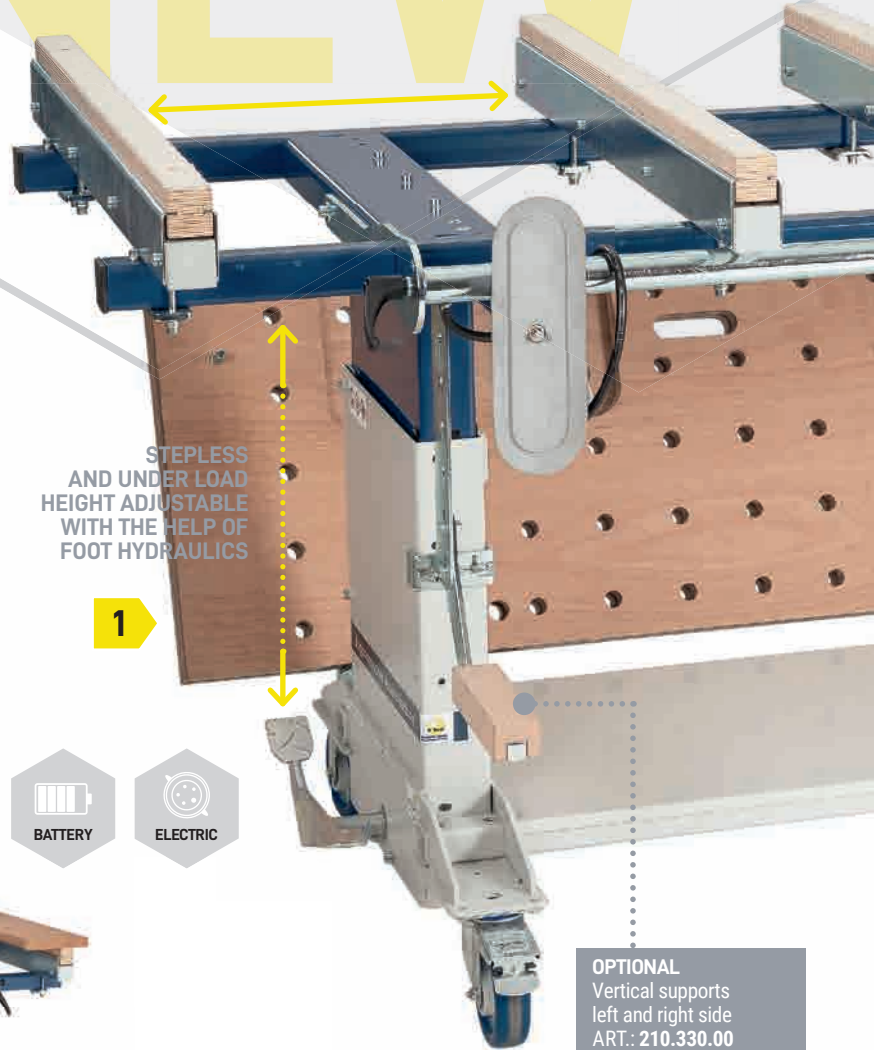

### VACUUM CLAMPING UNITS AND SUCTION CUPS

If required, the unit can be continuously rotated on an axis of rotation 90° and can be fixed vertically and horizontally with locking bolts at 0° - 45° - 90°. The vacuum suction cups can be exchanged using the quick-change system and are height-adjustable by 200 mm.

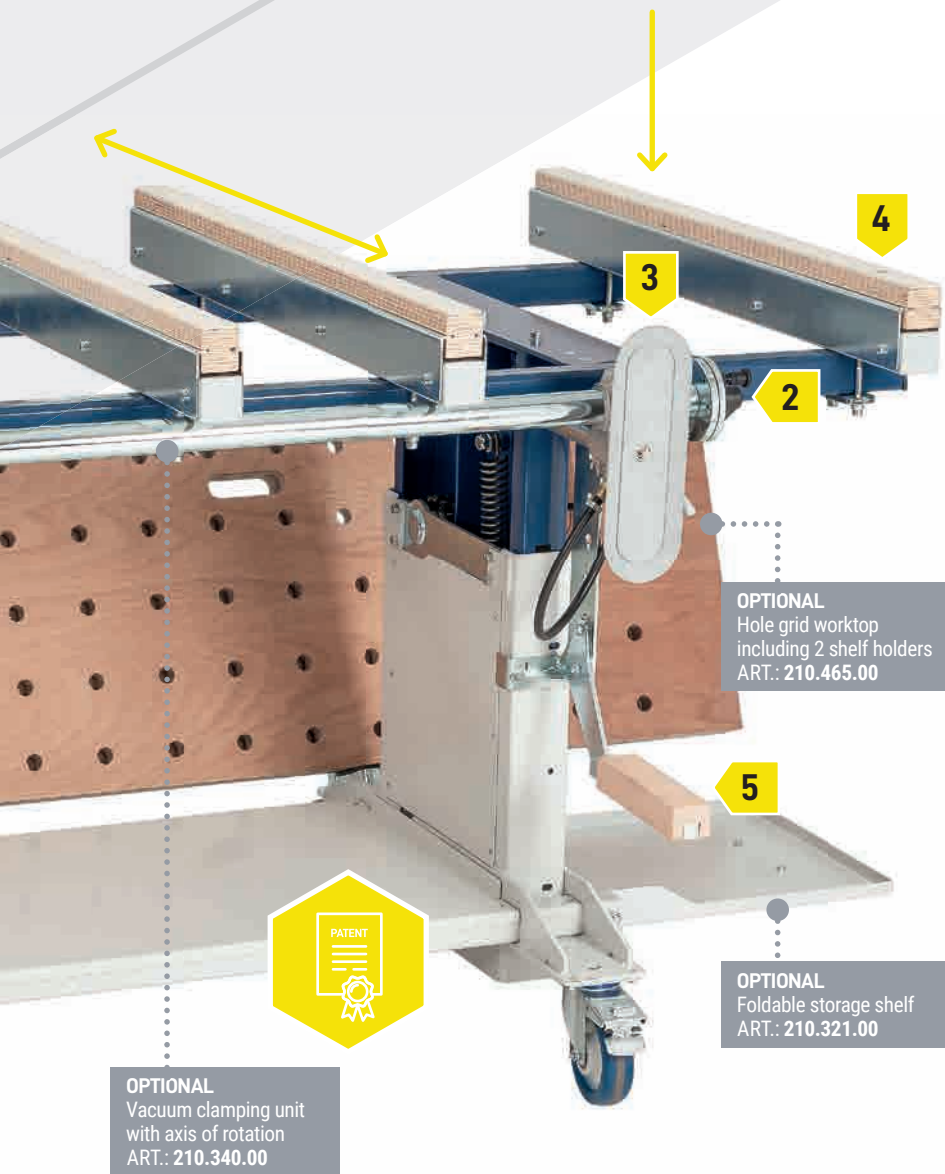

## HIGHLIGHT

THAT MAKE THE SUPPORTERS  
AM 500-FLEXX + AM 1200-FLEXX  
SPECIAL:



Rear supports for putting down the worktop.



Vacuum clamping unit with two sliding oval grippers with touch valve.



If necessary, the vacuum clamping unit can be folded away under the worktop.



Worktop can be removed quickly and easily for individual purposes.



Vertical support adjustable left and right in a 50mm keyhole grid.

# SUPPORTER

# OPTIONS

## EQUIPMENT SELECTABLE

The supporter can be individually and precisely adapted to the respective work area with additional equipment options such as a vacuum clamping unit, base cabinet or overhead device. Different versions enable different purposes for your industry-specific work process.

# OPTIC



### BEECH MULTIPLEX PERFORATED GRID PANEL, 2-PIECE – WITHOUT CUT-OUTS –

Suitable for Supporter AM 500-Flexx + AM 1200-Flexx, with 2 pieces of plug-in pins for attaching to the 2 outer support rails including 2 pieces of dovetail connectors (double T-connector), plate is coated with linseed oil

Plate format	2x 2,000 x 500 x 30 mm
Hole diameter	ø 22 mm
Hole grid spacing	T = 100 mm
Including 2 storage holders	
Weight	approx. 42 kg

ART.: 210.460.00  
\* without vacuum cup



### BEECH MULTIPLEX PERFORATED GRID PANEL, 2-TEILIG – WITH 2 CUT-OUTS –

Suitable for Supporter AM 500-Flexx + AM 1200-Flexx, 2 cutouts for vacuum cups oval (300 x 100 mm) with 2 pieces of plug-in pins for attaching to the 2 outer support rails including 2 pieces of dovetail connectors (double T-connector), plate is coated with linseed oil

Plate format	2x 2,000 x 500 x 30 mm
Hole diameter	ø 22 mm
Hole grid spacing	T = 100 mm
Including 2 storage holders	
Weight	approx. 42 kg

ART.: 210.465.00  
\* without vacuum cup



### PERFORATED GRID PANEL, BIRCH MULTIPLEX, HPL-COATED, 2-PIECE – WITHOUT CUT-OUTS –

Suitable for Supporter AM 500-Flexx + AM 1200-Flexx, with 4 pieces of socket pins to be attached to the 2 outer support rails including 2 pieces of dovetail connectors, the plate is coated with linseed oil

Plate format	2x 2,000 x 500 x 30 mm
Hole diameter	ø 22 mm
Hole grid spacing	T = 100 mm
Including 2 storage holders	
Color	White RAL 9016
Weight	approx. 42 kg

ART.: 210.312.00  
\* without vacuum cup



### PERFORATED GRID PANEL, BIRCH MULTIPLEX, HPL-COATED, 2-PIECE – WITH 2 CUT-OUTS –

Suitable for Supporter AM 500-Flexx + AM 1200-Flexx, 2 cutouts for vacuum cups oval (300 x 100 mm) with 4 socket pins for attaching to the 2 outer support rails including 2 pieces dovetail connectors, the plate is coated with linseed oil

Plate format	2x 2,000 x 500 x 30 mm
Hole diameter	ø 22 mm
Hole grid spacing	T = 100 mm
Including 2 storage holders	
Color	White RAL 9016
Weight	approx. 42 kg

ART.: 210.313.00  
\* without vacuum cup



### PULL-OUT SYSTEM ON ONE SIDE WITH HARDWOOD TOP

Platform extension by pulling out up to 820 mm per side, suitable for Supporter AM 500-Flexx + AM 1200-Flexx

Format per side	1,000 x 60 mm
Weight	approx. 20 kg

ART.: 210.314.00

### PULL-OUT SYSTEM LEFT AND RIGHT, WITH HARDWOOD TOP

Weight	approx. 40 kg
--------	---------------

ART.: 210.325.00



### VACUUM CLAMPING UNIT WITH ROTATING AXIS AND VACUUM SUCTION GRIPPERS

Suitable for all supporter models with vacuum, vacuum clamping unit with rotary axis can be swiveled continuously by 90° from vertical to horizontal for an optimal working position when machining workpieces, 2 sliding, oval vacuum suction grippers (exchangeable thanks to the quick-change system) with touch valve and holder, clamping unit can be completely retracted under the worktop

2x vacuum suction cups oval	300 x 100 mm
Weight	approx. 20 kg

ART.: 210.340.00

Without foot switch and without vacuum pump



### ELECTRIC VACUUM PUMP IN MOBILE CARRYING BOX

Suitable for all supporter models with vacuum, can be placed on the lower shelf, dry-running and low-maintenance electric vacuum pump with vacuum tank and automatic switch-off in a mobile carrying box, with 2 connection sockets

Suction capacity	3.0 m³/h
Foot switch	1,5 m fabric hose
Connection cable	5 m (schuko plug)
Weight	approx. 20 kg

ART.: 210.440.00



### VACUUM PUMP WITH STRONGER SUCTION POWER

Suitable for all supporter models with vacuum, with 2 connection coupling sockets

Suction capacity	4.6 m³/h (anstatt 3.0 m³/h)
Foot switch	1.5 m fabric hose
Connection cable	5 m (schuko plug)
Power connection	230V / 50Hz
Weight	approx. 20 kg

ART.: 210.450.00



### VACUUM SUCTION GRIPPER, OVAL

Suitable for all supporter models with vacuum, with tactile valve and holder, exchangeable with quick-change system

Infinitely height adjustable	200 mm
Weight	approx. 3 kg

Size	300 x 100 mm
------	--------------

ART.: 210.341.00

Size	300 x 30 mm
------	-------------

ART.: 210.359.00



### VACUUM SUCTION GRIPPER, ROUND

Suitable for the rotary axis with the vacuum system, the vacuum suction grippers can be exchanged using the quick-change system

Infinitely height adjustable	200 mm
Weight	approx. 3 kg

ø 100 mm	ART.: 210.342.00
----------	------------------

ø 125 mm	ART.: 210.343.00
----------	------------------

ø 200 mm	ART.: 210.347.00
----------	------------------



### VERTICAL SUPPORT, LEFT AND RIGHT SIDE

Suitable for all supporter models, adjustable in height using a 50 mm keyhole grid

Weight	approx. 10 kg
--------	---------------

ART.: 210.330.00



### FOLDING SHELF, RIGHT SIDE

Suitable for all Supporter models, attached to the lower frame on the right side, offers space for tools, accessories, vacuum cleaner, vacuum pump, etc.

Support format	445 x 390 mm
Weight	approx. 12 kg

ART.: 210.321.00



### VERSATILE EQUIPMENT FOR PERFORATED GRID PANELS

Perforated grid panels are versatile and, with their accessories, offer solutions for optimized processes: clamping, gluing, pressing, grinding, polishing, etc. can be carried out on your lifting table with little effort.

**EQUIPMENT // FROM P.111**