

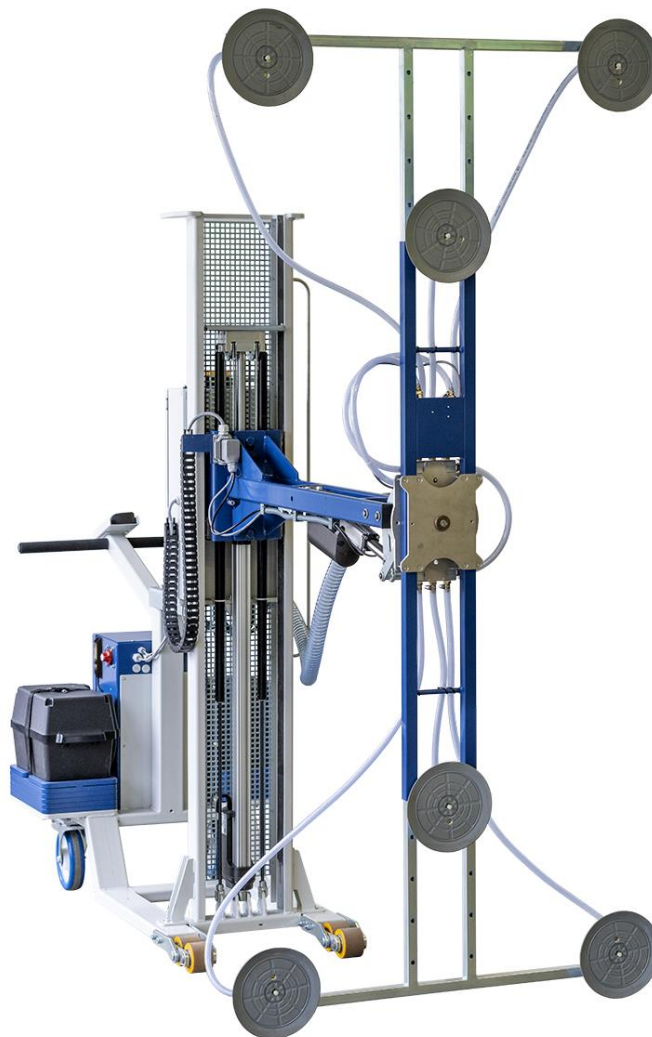

Operating Manual

Mobile Lifter Type ML-120

Ergonomic vacuum lifter & handling device for large panels



Valid for: **Mobile Lifter Type ML-120**

Space for notes:

Reinhold Beck Maschinenbau GmbH
 Im Grund 23, DE 72505 Krauchenwies
 Phone: +49 (0) 7576 962978-0
 Fax: +49 (0) 7576 962978-90

Handover Certificate

Machine type:		
Machine no.:		
Construction year:		
Customer address (location of the machine):		
Name:		
Street:		
Postcode/City:		
Phone:		
E-mail:		
Warranty:		
<p>On the basis of our Terms and Conditions of Sale, Delivery and Payment of the respective current status, we assume a warranty of 12 months, calculated from the day of delivery, for material defects and defects of title in connection with the delivery for the above-mentioned machine.</p>		
Warranty claims:		
<p>Warranty claims against R. Beck Maschinenbau GmbH are only valid if this handover declaration has been completed, signed and handed over to R. Beck Maschinenbau GmbH and the machine has been properly put into operation.</p>		
Important: Please read and follow the instructions in chapter ⇒ 1 " <u>Liability and Warranty</u> ".		
Confirmation of the buyer:		
<ul style="list-style-type: none"> ✓ The machine described above was purchased by the buyer. ✓ The machine was handed over with the corresponding operating manual, edition: _____ ✓ The contents of the operating manual are acknowledged by the buyer. ✓ Persons who are commissioned to work on this machine will be provided with the operating manual and will receive safety training. 		
_____	_____	_____
Name and position	Date	Signature of the customer
Address of the dealer (company stamp):		The machine, including the operating manual, was handed over to the buyer and installed according to the specifications in the operating manual.

		Date Signature - Customer Service

Space for notes:

Reinhold Beck Maschinenbau GmbH
 Im Grund 23, DE 72505 Krauchenwies
 Phone: +49 (0) 7576 962978-0
 Fax: +49 (0) 7576 962978-90

<h1>Handover Certificate</h1>		
Machine type:		
Machine no.:		
Construction year:		
Customer address (location of the machine):		
Name:		
Street:		
Postcode/City:		
Phone:		
E-mail:		
Warranty:		
<p>On the basis of our Terms and Conditions of Sale, Delivery and Payment of the respective current status, we assume a warranty of 12 months, calculated from the day of delivery, for material defects and defects of title in connection with the delivery for the above-mentioned machine.</p>		
Warranty claims:		
<p>Warranty claims against R. Beck Maschinenbau GmbH are only valid if this handover declaration has been completed, signed and handed over to R. Beck Maschinenbau GmbH and the machine has been properly put into operation.</p>		
<p>Important: Please read and follow the instructions in chapter ⇨ 1 "<u>Liability and Warranty</u>".</p>		
Confirmation of the buyer:		
<ul style="list-style-type: none"> ✓ The machine described above was purchased by the buyer. ✓ The machine was handed over with the corresponding operating manual, edition: _____ ✓ The contents of the operating manual are acknowledged by the buyer. ✓ Persons who are commissioned to work on this machine will be provided with the operating manual and will receive safety training. 		
_____	_____	_____
Name and position	Date	Signature of the customer
Address of the dealer (company stamp):		<p>The machine, including the operating manual, was handed over to the buyer and installed according to the specifications in the operating manual.</p>

		Date
		Signature - Customer Service

Table of Contents

1	Liability and warranty	9
2	Introduction	10
2.1	Legal notice	10
2.2	Illustrations	10
3	Symbols	10
3.1	General symbols	10
3.2	Symbols in safety instructions	11
4	General	12
4.1	Application	12
4.2	Target group and previous experience	12
4.3	Requirements for the operators	12
4.4	Accident prevention	13
4.5	General safety regulations	13
4.6	Standard equipment	13
5	Safety	14
5.1	Basic safety instructions	14
5.2	Application area and intended use	14
5.3	Improper use	14
5.4	Consequences in case of disregard	15
5.5	Conversions and modifications of the Mobile Lifter	15
5.6	Load distribution and influence on the nominal load	15
5.7	Hazardous areas	16
5.8	Residual risks	17
5.9	Observe the environmental protection regulations	17
5.10	Organisational measures	18
5.11	Personnel selection and qualification - basic duties	18
6	Technical specifications	19
6.1	Nameplate and manufacturer	20
7	Dimensions	21
8	Transport to the installation site	22
8.1	Unloading the Mobile Lifter	22
8.1.1	Unloading from the transport vehicle using a forklift truck	22
8.1.2	Unloading from the pallet using a forklift truck or crane	22
8.1.3	Check delivery condition	23
8.1.4	Unpacking and placing	23
8.1.5	Transport to the installation site	23
8.2	Requirements for the installation site	23
8.3	Temporary storage	23
8.3.1	Short term storage	23
8.3.2	Long term storage	23
8.4	Lashing on a transport vehicle	24
9	Components and controls	25

10	Installation and commissioning	26
11	Operating the Mobile Lifter	26
11.1	Switching ON the Mobile Lifter ML-120	26
11.2	Adjustment options	27
11.3	Using the radio remote control	27
11.3.1	Storage compartment and charging station	27
11.3.2	Remote control cunctions	28
11.4	Lifting and tilting the clamping platform	29
11.5	Rotating and swivelling the clamping platform	29
11.6	Moving the Mobile Lifter via castors	29
11.7	Battery monitoring	30
11.8	Vacuum clamping device with pressure switch	30
11.9	Requirements for clamping panels	31
11.10	Clamping panel material	31
11.11	Loosen a clamped panel	31
11.12	Adjusting the vacuum pad positions	32
11.13	Measures after operation	32
11.13.1	Pulling off the main switch handle	32
12	Battery charger CBHF2 24-30	33
12.1	General information and warnings	33
12.2	Operating and display elements	33
12.3	Charging the battery unit	34
12.4	Possible faults	34
12.5	Additional notes on lead-acid batteries	34
13	Troubleshooting	35
14	Maintenance and repair	36
14.1	General maintenance intervals	36
14.2	Check mechanical equipment	36
14.3	Check electrical equipment	36
14.4	Check pneumatic equipment	36
14.5	Maintenance of the charging contacts for the remote control	37
14.6	Maintenance of the vacuum pump	37
15	Decommissioning	37
16	Disassembly and scrapping	38
17	Spare parts	39
17.1	General	39
17.2	Recommended spare parts	39
17.3	Return of parts	39
17.4	Ordering spare parts	39
	EU - Declaration of Conformity	40

List of Figures

Figure 1: Load distribution	15
Figure 2: Nameplate.....	20
Figure 3: Dimensions ML-120	21
Figure 4: Transport eyelet.....	22
Figure 5: Securing the Mobile Lifter to the pallet	24
Figure 6: Components and controls ML-120.....	25
Figure 7: Main switch.....	26
Figure 8: Adjustment options ML-120	27
Figure 9: Storage compartment directly on the handlebar	27
Figure 10: Charging station next to the main switch	27
Figure 11: Radio remote control	28
Figure 12: Rotation and tilt adjustment	29
Figure 13: Locking bolts	29
Figure 14: Swivel castors and handlebar.....	29
Figure 15: Battery monitor unit	30
Figure 16: Vacuum unit	30
Figure 17: Vacuum pads.....	30
Figure 18: Digital pressure switch	30
Figure 19: Vacuum pad clamping side	31
Figure 20: Adjusting the vacuum pad positions	32
Figure 21: Securing the main switch	32
Figure 22: Battery charger	33
Figure 23: Charging cable in the plugged-in state.....	33
Figure 24: Vacuum pump with filter inserts and carbon sliders	37

Revisions:

Revision	Editor	Modification	Date
000	AG	Translation of the German original operating manual	21/03/2023
001	AG	Section ⇒ 8.4 revised (only lashing of pallets) and new drawing added	20/07/2023
002	AG	Section ⇒ 14.6 "Maintenance of the vacuum pump" revised resp. expanded	15/04/2024

1 Liability and warranty

When purchasing a machine or work equipment (hereinafter referred to as "machine"), the General Terms and Conditions of Sale and Delivery of Reinhold Beck Maschinenbau GmbH generally apply. These are provided to the purchaser or operator at the latest when the contract is concluded.



IMPORTANT NOTE: Liability and warranty claims shall only commence from the point in time at which the signed handover certificate (see ⇒ page 3 resp. page 5) from the dealer and/or end customer for the delivered machine has been submitted to Reinhold Beck Maschinenbau GmbH in written form.

Liability and warranty claims for personal injury and property damage are generally excluded if they are due to one or more of the following causes:

- Commissioning of the machine without prior machine instruction by an authorised and adequately trained specialist who is familiar with the function and dangers of the machine.
- Electrical connection as well as repair and/or maintenance work on electrical components by personnel who do not have the appropriate qualifications.
- Connection and repair and/or maintenance work on hydraulic or pneumatic components by personnel who do not have the appropriate qualifications.
- Non-observance of the instructions in the operating manual, in particular the chapter "Safety".
- Improper use or operation in an unauthorised area of application.
- Improper assembly, commissioning, operation and maintenance of the machine.
- Unauthorised conversions or modifications to the machine or additional components.
- Operating the machine without using all the protective equipment available for the operation.
- Inadequate monitoring and maintenance of the machine components and protective devices.
- Continuing to operate the machine when faults, damage or defects are present.
- Processing materials that do not correspond to the machine's area of application.
- Carrying out operations that are not permitted for the machine supplied.
- Use of tools that are not permitted for the machine supplied.
- Operating the machine outdoors or in damp, wet or potentially explosive environments.
- Operation of the machine outside permissible ambient temperatures or humidity.
- Grossly negligent behaviour when handling or operating the machine.
- Impact by foreign bodies, e.g. stones, metal parts, etc.
- Improperly carried out repairs.
- Catastrophic events due to force majeure.

2 Introduction

The information in this operating manual enables safe, proper and economical operation of your Mobile Lifter. Please observe all the explanations, notes and regulations

- to avoid dangers and malfunctions,
- to reduce repair costs and downtimes
- and to increase reliability and service life

of your Mobile Lifter.

The operating manual must be read and used by each person entrusted with carrying out work with the Mobile Lifter. This must be ensured by the operator. Further this manual as well as any appendices and additional documents must be kept easily accessible at the place of use of the Mobile Lifter.

	<p><i>Ignorance or non-observance of these operating instructions may result in certain accident hazards during <u>handling</u> with the Mobile Lifter. Before commissioning, this operating manual and any appendices and additional documents must be read thoroughly. All instructions, in particular the safety regulations, must be observed!</i></p> <p><i>Handling</i> the Mobile Lifter in the sense of these instructions means</p> <ul style="list-style-type: none"> • the installation and commissioning, • the operation and proper usage, • the influence on operating conditions, as well as • the maintenance, troubleshooting and repair.
---	--

Apart from the operating manual and the legally binding accident prevention provisions applicable in the country and place of use, the recognized technical regulations for safe and proper work must also be observed.

2.1 Legal notice



All contents of these operating instructions are subject to the rights of use and copyright of Reinhold Beck Maschinenbau GmbH. Any reproduction, modification, further use and publication in other electronic or printed media, as well as their online publication, requires the prior written consent of Reinhold Beck Maschinenbau GmbH.

2.2 Illustrations

All photos, figures and graphics contained in this document are for illustration and better understanding only and may differ from the current state of the product.

3 Symbols











3.1 General symbols

Symbol	Meaning
	Indicates passages within this operating manual that must be particularly observed in order to prevent malfunctions or damage to the Mobile Lifter.
	Refers to chapters, sections, or figures within this document.
	Refers to an external document or a third-party source.

3.2 Symbols in safety instructions

The Mobile Lifter is designed and manufactured according to the current state of the art. Nevertheless, residual hazards may occur during handling. In this operating manual, possible dangers and residual risks are pointed out at appropriate places.

Safety instructions are provided with corresponding danger symbols which have the following meanings:

Symbol	Safety Instruction
	Reading and applying the operating manual is mandatory for the operating personnel. <i>Failure to abide by the following precautions could lead to serious or possibly fatal injury.</i>
	General danger symbol, which requires the highest attention! <i>Failure to observe may result in damage to the equipment, serious injury or even death.</i>
	This symbol warns of the dangers of electric voltage! <i>Failure to observe may result in damage to the equipment, serious injury or even death.</i>
	Reference to a prohibited zone under a lifted load! <i>Do not enter! There is an increased risk of injury or even death.</i>
	Reference to a prohibited zone on a platform! <i>Do not enter! There is an increased risk of injury or even death.</i>
	Reference to a possible crushing hazard! <i>Non-observance increases the risk of injury to hands and fingers!</i>
	Reference to a possible crushing hazard! <i>Non-observance increases the risk of injury to feet and toes!</i>
	Possible dangerous crushing hazard in the area of stationary objects! <i>Risk of personal injury and possibly additional equipment damage.</i>
	Reference to a possible hazard due to forklift traffic! <i>Non-observance can result in life-threatening injuries.</i>
	Reference to a possible danger under suspended loads! <i>Non-observance can result in life-threatening injuries.</i>
	Reference to possible tripping and slipping hazards on the floor! <i>Non-observance may result in minor or severe injuries.</i>
	Reference to possible environmental pollution! <i>Non-observance poses a risk of pollution of the environment and groundwater!</i>
	Reference to the obligation to wear safety shoes resp. protective gloves! <i>Non-observance may result in increased risk of injury to feet & toes or hands & fingers!</i>
	Fire hazard! Do not smoke and do not ignite open fire.
	Access for unauthorized persons prohibited! <i>Risk of personal injury and possibly additional equipment damage.</i>

4 General



The operating manual must be read carefully and understood before using the Mobile Lifter! If you have any questions, please contact the manufacturer.

The ergonomic Mobile Lifter ML-120 is used for panel handling of large-format panels in the upright panel storage. With its high load capacity of 120 kg and six powerful vacuum pads, the Mobile Lifter enables you to lift and transport panels up to a size of 2,100 x 3,200 mm without using your own physical strength. The Mobile Lifter is designed for the following applications:

- Turning large-format panels from vertical to horizontal
- Feeding large-format panels to a processing machine
- Transporting large-format panels from the warehouse to the machine hall
- Feeding large-format panels to a panel saw

4.1 Application

- The Mobile Lifter can be used for all work that corresponds to its intended use (see section ⇒ 5).
- The Mobile Lifter must not be used for work that does not correspond to its intended use (section ⇒ 5.3).

4.2 Target group and previous experience

This operating manual is intended for the operating and maintenance personnel of the Mobile Lifter. The operating personnel is to be determined by the operator and must further meet the following requirements:

- Basic technical and mechanical knowledge as well as knowledge of the associated technical terms
- Reading and understanding these operating and maintenance instructions

In order to acquire the knowledge required to operate this Mobile Lifter, the operator must ensure the following measures:

- Product training for every operator (also possible external personnel)
- Regular safety instruction

4.3 Requirements for the operators

- The operator is responsible for the safe use of the Mobile Lifter!
- The Mobile Lifter may only be operated by trained personnel who have also read this manual.
- Inspection, maintenance, cleaning and repair may only be performed by technical specialists with product-specific training and mechanical and/or electrical training.
- Specialists with product-specific training are to be commissioned and held responsible for planning and checking the work.
- The national protective regulations for employees must be observed
- The legal minimum age must be observed.

4.4 Accident prevention

To avoid accidents, the following rules must be observed for operation:

- ⚠ Prevent unauthorized persons from gaining access to the Mobile Lifter.
- ⚠ Keep unauthorized persons away from the danger areas.
- ⚠ Repeatedly inform present other persons about existing residual risks (see section ⇒ 5.8 “Residual Risks”)
- ⚠ Conduct and record regular training & instruction for persons who must be in the area of the Mobile Lifter.
- ⚠ New employees must be trained to work on the Mobile Lifter and this training must be documented.
- ⚠ It is not permitted to enter the Mobile Lifter platform or to transport resp. lift persons.

4.5 General safety regulations

In general, the following safety regulations and obligations apply when handling the Mobile Lifter:

- ⚠ The Mobile Lifter may only be operated when it is in perfect working order.
- ⚠ It is prohibited to remove, modify or bypass any protective, safety or monitoring equipment.
- ⚠ Wearing appropriate protective clothing and safety shoes is a basic requirement for any work with and on the Mobile Lifter.
- ⚠ Wearing loose clothing, watches, jewellery and loose long hair is prohibited.
- ⚠ The regulations of the employers' liability insurance association and building regulations must be observed.
- ⚠ It is prohibited to modify the Mobile Lifter without the written approval of the manufacturer / supplier.
- ⚠ Malfunctions or damage must be reported to the operator immediately. These must be rectified immediately and repaired if necessary.
- ⚠ Repair and maintenance work on mechanical, electrical and pneumatic components may only be carried out by authorised and trained specialist personnel.
- ⚠ Maintenance work must be carried out and documented in accordance with the maintenance instructions.
- ⚠ Only original spare parts from the manufacturer may be used for repairs.
- ⚠ Only instructed, trained or qualified persons may work on the Mobile Lifter.
- ⚠ Ensure that the Mobile Lifter is only used on a firm, level and horizontal surface. Use on sloping ground or downhill slopes is prohibited due to the high dead weight!
- ⚠ When loading and unloading a load, as well as when the Mobile Lifter is parked unattended, the brakes on the rear castors must be tightened to prevent it from rolling away unintentionally.
- ⚠ For the operation of the Mobile Lifter, the respective national safety regulations for employees as well as the national safety and accident prevention regulations apply.

4.6 Standard equipment

The Mobile Lifter ML-120 consists of the following main components:

- Mobile and steerable base frame
- Electromotive lifting and tilting system
- Manually adjustable swivelling and rotating mechanism
- Automatic vacuum unit with six vacuum pads
- Wireless, electronic operation via remote control
- 24 VDC battery unit with charger and charging cable

5 Safety

5.1 Basic safety instructions

Lift tables can be dangerous if used improperly. Therefore, observe the safety instructions listed in this chapter and the accident prevention regulations of your employer's liability insurance association!

	<i>The manufacturer accepts no liability for damage and malfunctions resulting from failure to observe these operating instructions.</i>
---	---

5.2 Application area and intended use

With its conformity to the Machinery Directive 2006/42/EC, the ergonomic Mobile Lifter ML-120 is suitable as a technical aid for industrial and commercial applications.

	<i>Improper use may endanger persons and result in a defect or damage to the Mobile Lifter.</i>
---	--

- ⚠ The Mobile Lifter is designed for lifting, lowering and moving large format panels up to 120 kg.
- ⚠ The maximum lifting and carrying capacity of 120 kg must not be exceeded in any application.
- ⚠ The Mobile Lifter is only suitable for clamping absorbent panel material.
- ⚠ The Mobile Lifter is primarily intended for use in covered indoor areas.
- ⚠ Work on the Mobile Lifter may only be carried out in adequately lit working areas.
- ⚠ The Mobile Lifter may only be moved if the driver has sufficient visibility of the route or is assisted by a person called in for instruction.
- ⚠ The Mobile Lifter may only be used on horizontal floors for lifting and moving loads.
- ⚠ During a movement with a suspended load, the load must generally be lowered as far as possible (floor-free) in order to keep a possible fall distance and the associated dangers as low as possible.
- ⚠ A load raised higher than floor-free is only permitted for picking up and setting down the load.
- ⚠ The Mobile Lifter must be positioned freely in the room when lifting and lowering. This means that the positioning of the Mobile Lifter must not cause any shearing or crushing edges.
- ⚠ During movement with the Mobile Lifter, the travel speed must be adapted to the respective environment.
- ⚠ The Mobile Lifter is not intended for riding or transporting persons.
- ⚠ The Mobile Lifter must not be operated in potentially explosive working areas.
- ⚠ It must always be prevented that vacuum hoses are kinked or pinched.

Any other use is considered improper and prohibited.

Apart from the safety devices already in place, further safety measures may be required on the Mobile Lifter depending on the type of application. Discuss appropriate measures with your Beck Maschinenbau GmbH representative or with the Employer's Liability Insurance Association. We also recommend carrying out a risk assessment in accordance with the Machinery Directives.

5.3 Improper use

Improper use is when the Mobile Lifter is used in a manner other than that specified in this operating manual and in section ⇒ 5, for example

- ⚠ using the Mobile Lifter with the protective grille not fitted and/or the covers open,
- ⚠ clamping of unsuitable (rough, porous and/or air-permeable) panel material,
- ⚠ usage and application for private or non-commercial purposes,
- ⚠ using in disregard of the instructions in the operating manual,
- ⚠ using after unauthorised conversions or modifications,
- ⚠ using in insufficiently lit rooms and areas,
- ⚠ using of the Mobile Lifter on uneven floors and slopes,
- ⚠ exceeding the maximum permissible load (see ⇒ 6 "Technical Specifications"),
- ⚠ transporting or carrying persons with the Mobile Lifter
- ⚠ as well as entering the Mobile Lifter.

In case of improper use of the Mobile Lifter, any warranty, liability and other claims for damages of the operator against the manufacturer are excluded!

5.4 Consequences in case of disregard

If the Mobile Lifter is not operated, maintained or repaired in accordance with the safety regulations, not as intended, improperly or in an abusive manner, the following will result:

- ⚠ Dangers to the health of the operating personnel
- ⚠ Dangers to the Mobile Lifter and objects in its vicinity
- ⚠ Impairment of the Mobile Lifter function

In case of improper use of the Mobile Lifter, any warranty, liability and other claims for damages of the operator against the manufacturer are excluded!

5.5 Conversions and modifications of the Mobile Lifter

- ⚠ Only use the Mobile Lifter in its original condition, i.e. as delivered!
- ⚠ The components of the Mobile Lifter must not be changed in their type and condition.
- ⚠ The factory settings of electrical and pneumatic devices must not be changed.
- ⚠ Only original spare parts and accessories from the manufacturer may be used.
- ⚠ Deviations are not permitted!

	<p><i>Unauthorized modifications or conversions by the operator, without the written consent of the manufacturer, are prohibited. This excludes any warranty, liability and other claims for damages by the operator against the manufacturer!</i></p>
---	---

5.6 Load distribution and influence on the nominal load

The nominal value of the maximum permissible lifting and carrying load of 120 kg is based on a load distributed uniformly on the vacuum clamping device of the Mobile Lifter. To avoid non-uniform load distribution, a panel to be clamped should therefore always be aligned as centrally as possible to the six vacuum pads resp. to the centre axis before it is clamped via vacuum (see the following figures).

Uniform load distribution:

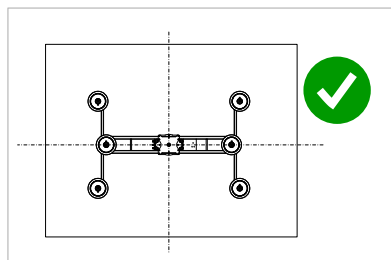

Uniform load distribution:

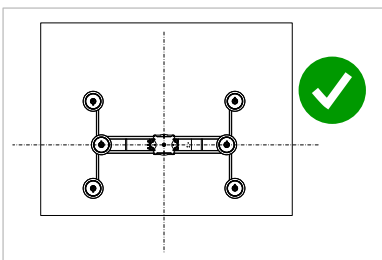

Non-uniform load distribution:

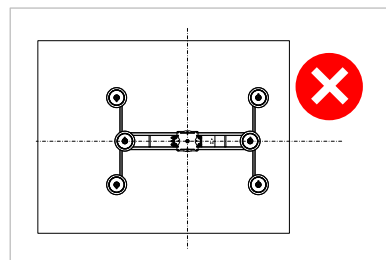





Figure 1: Load distribution

Remark: The four outer vacuum pads and the two inner support rails can be adjusted by sliding to ensure optimum load distribution.

For details about adjusting the positions of the vacuum pads, refer to section ⇒ 11.12.























5.7 Hazardous areas

Source	Area	Hazards	Risk	Avoidance
Working area 	Around the Mobile Lifter, especially when moving with a clamped load, as the view to the front is very restricted by a clamped panel. Further hazards due to swivelling, tilting, rotating and adjusting the height of a suspended load.	<ul style="list-style-type: none"> • Bumping and crushing of persons and body parts • Dangerous tipping or falling of the suspended load. • Driving over persons 	Mild, moderate and severe impact, shearing or crushing injuries or even death.	When moving, make sure that there are no persons in front of a suspended panel (limited visibility!). Keep people out of the moving area of the Mobile Lifter. If necessary, call in a second person to give instruction and to and secure the moving area. Before a movement with a load, always check that the load is securely clamped over all six vacuum pads and that the red warning lamp is off. During load adjustment, stationary operation and movement via the castors, no persons may be under or in the immediate vicinity of the load.
Mechanic 	On all mechanically movable parts (e.g. lift mast mechanics) as well as on all manually or motorised adjustable components.	Bump, crush and shear points	Loss of limbs, bruising of the hands, increased risk of injury or even death.	Never reach into the movement area or move your body into this area during manual or motorised adjustment. Always keep the protective grille closed and never work without the protective grille. Open hair, loose clothing, watches and jewellery are prohibited. Keep other persons (e.g. observers) out of the danger zones.
Pneumatic 	Vacuum pump with open housing.	Outflowing air, gases and dust	Injuries of the eyes and respiratory tract.	Always keep the housing closed during operation. Do not look into the openings of the pump when the housing is open. Wear protective goggles and a respirator mask if necessary.
Electric 	On the mains connection and the supply line of the battery charger, on the pole terminals of the two batteries and on all live components when the enclosures or covers are open.	Electrical voltage (230 VAC) at the supply line and at the input of the battery charger. High currents at the battery terminals as well as at all further conductors.	Electric shocks with increased risk of injury or even death! WARNING! Danger of electric shock at the battery terminals and cables <u>even when the main switch is off!</u>	Avoid moisture Have defective parts / insulation repaired immediately (only by qualified electricians!). Always keep the housing and covers closed (only qualified electricians are allowed to open them!). Do not touch live components. Switch off the main switch during all maintenance and repair work.

Further hazard sources can be found in the next section ⇒ 5.8 “Residual Risks”.



5.8 Residual risks

The Mobile Lifter is built according to the latest state of the art and the recognised safety rules. Nevertheless, the use of the Mobile Lifter may cause danger to life and limb of the user or third parties or damage to the Mobile Lifter and other equipment. Due to the construction of the Mobile Lifter, the following residual risks can occur even when used as intended and despite compliance with all relevant safety regulations:

	Reading and applying the operating manual is mandatory for the operating personnel.
 	Be alert to possible crushing hazards: a) when transporting the Mobile Lifter by forklift truck: between forks & pallet / Mobile Lifter b) when picking up the Mobile Lifter: between Mobile Lifter / pallet and floor c) when lowering the Mobile Lifter: between Mobile Lifter and fixed equipment
 	Be alert to possible crushing hazards when lowering the Mobile Lifter (from the cargo pallet to the floor) with a forklift truck or overhead crane.
 	Be aware of the danger from falling objects such as workpieces, tools or similar. Therefore, wear safety shoes, especially when transporting and setting down the Mobile Lifter.
	It is strictly forbidden to “ride along” with the Mobile Lifter during a lifting operation (by means of a forklift truck or overhead crane). There is a high risk of falling!
	It is strictly forbidden to enter or climb onto the Mobile Lifter during a lifting operation (by means of a forklift truck or overhead crane). There is a high risk of falling!
	Increased risk of injury or even death. Entering the danger zone under a lifted load during transport or installation by means of a forklift truck is prohibited!
	Increased risk of injury or even death. It is forbidden to enter the forklift platform during transport or installation!
	Unauthorised persons are not allowed to enter the installation area or the movement area of the Mobile Lifter (responsibility of the operator).
	Stop! Staying under a lifted load is prohibited. Increased risk of injury or even death for persons standing under a lifted or suspended load!
 	Danger due to electric shock! Work on the electrical components, batteries and vacuum pump may only be carried out by qualified personnel.
 	Be aware of possible tripping and slipping hazards on the floor. Prevent possible hazards by keeping the floor dry and clean and by using anti-slip floor coverings around the Mobile Lifter.
	Acute danger of crushing underneath the table top! Never reach into the shears and never move your body into this area! There is an increased risk of accidents with loss of limbs or even death.
 	When using additional machines on the Mobile Lifter, first read the respective operating instructions and comply with the specified safety regulations.
 	Be aware of the fire hazard during the processing of wood due to wood dust, in connection with flying sparks and/or open fire!

5.9 Observe the environmental protection regulations

During all work with the Mobile Lifter, the environmental protection regulations, obligations and laws for waste avoidance and proper recycling and/or disposal applicable at the place of use must be observed. This applies in particular to installation, repair and maintenance work involving substances that could pollute the groundwater (e.g. lubricants and cleaning agents and liquids containing solvents). In any case, prevent them from seeping into the ground or entering the sewage system.

 	Store and transport the above-mentioned hazardous substances only in suitable containers. Avoid leakage of hazardous substances by using suitable collection containers. Ensure that the above-mentioned substances are disposed of by a qualified disposal company.
---	---

5.10 Organisational measures

- ⚠ Always keep this operating manual within easy reach and at the place of use of the Mobile Lifter.
- ⚠ In addition to the operating manual, observe and instruct on generally applicable legal and other binding regulations for accident prevention and environmental protection.
- ⚠ Supplement the operating manual with further instructions, including supervisory and reporting duties, to take account of special operational features (e.g. with regard to work organisation, work processes, personnel employed).
- ⚠ Before starting work on the Mobile Lifter, the person responsible for its operation must have read the operating instructions, especially the chapter ⇒ 5 “Safety”. This applies in particular to personnel who only occasionally work on the Mobile Lifter.
- ⚠ Check that work is carried out in a safety-conscious and hazard-conscious manner and in compliance with the operating manual.
- ⚠ When using additional machines on the Mobile Lifter, read the respective operating instructions and keep them handy. Pay particular attention to the respective safety and hazard information.
- ⚠ In case of safety-relevant changes to the Mobile Lifter or its operating behaviour, shut down the entire system immediately and report the fault to the responsible office/person.
- ⚠ Use personal protective equipment as necessary or required by regulations.
- ⚠ Do not make any modifications, additional attachments or conversions to the Mobile Lifter without the manufacturer's approval! This will compromise safety and invalidate the manufacturer's warranty and any liability claim.
- ⚠ Spare parts must meet the technical requirements specified by the manufacturer. The exclusive use of original spare parts ensures this. Therefore, only use original spare parts from the manufacturer.
- ⚠ Observe the fire alarm and firefighting possibilities. Make the location and operation of fire extinguishers (fire class ABC) known. Do not use water!

5.11 Personnel selection and qualification - basic duties

- ⚠ The design and operation of the Mobile Lifter is equally suitable for right- and left-handers.
- ⚠ The Mobile Lifter is designed to be operated by a single person. Other persons in the vicinity of the Mobile Lifter must keep a suitable safety distance.
- ⚠ Work on and with the Mobile Lifter may only be carried out by reliable personnel. Observe the legal minimum age!
- ⚠ Only use trained or instructed personnel. Clearly define the responsibilities of the personnel for operating, setting up, maintaining and repairing!
- ⚠ Ensure that only authorised personnel work on the Mobile Lifter!
- ⚠ If personnel to be trained or apprenticed have to work on the Mobile Lifter, this may only be done under the constant supervision of an experienced resp. qualified person.
- ⚠ Work on pneumatic equipment may only be carried out by authorised and trained personnel.
- ⚠ Work on the electrical equipment of the Mobile Lifter may only be carried out by a qualified electrician or by instructed persons under the direction and supervision of a qualified electrician in accordance with the electrotechnical regulations.

6 Technical specifications

Mobile Lifter ML-120	
Article number	350.100.00
Height adjustment range	up to max. 1600 mm (electromotive)
Tilt range (vertical)	-90° ... 0 ... +90° (electromotive)
Swivel range (horizontal)	-85° / 0° / +85° (manually) positions lockable
Rotation range (frontal)	0 ... 270° (manually) lockable in 90° steps
Lifting and load capacity	max. 120 kg
Panel size to be lifted	max. 2,100 x 3,200 mm
Actuators	2 pcs. 24 VDC linear actuators Linak type LA 36
Front castors	4 Ø 82 mm lift carriage castors (rigid)
Rear castors	2 Ø 200 mm swivel castors with brake
Dimensions	L x H x W = 2680 x 2090 x 1710 mm (dimensional drawing see chapter ⇒ 0)
Empty weight	approx. 440 kg
Wireless control unit	
Components	1 piece radio remote control as transmitter + 1 stationary receiver with antenna
Frequency band	433.075 – 434.75 MHz
Operating time remote control	approx. 24 hours (for continuous operation)
Transmitter power supply	integrated lithium-ion battery, rechargeable via fixed charging station
Charging unit power supply	24 VDC from ML-120 battery unit (see below)
Remote control buttons	4 function button pairs + 1 combined off/emergency stop button
Receiver power supply	24 VDC from ML-120 battery unit (see below)
Safety levels	EN 61508 SIL3 and EN ISO 13849 PLc (emergency stop function)
Protection class	Transmitter: IP65 Charging unit for transmitter: IP40 Receiver: IP66
Vacuum unit	
Vacuum generator	24 VDC / 500 W glanded pump
Product info (pump)	Manufacturer: Schmalz Type: EVE-TR 8 24V-DC F
Pumping speed	9.70 m ³ /h
Sound level	60.5 dB(A)
Vacuum pad	6 round vacuum suction pads (Ø 210 mm), 4 of them shiftable
Connection type	G1/2"-IG
Product info (vacuum pads)	Manufacturer: Schmalz Type: SPU 210 NBR-55 G1/2-IG
ML-120 battery unit	
Batteries	2 pieces maintenance-free 12 V lead-acid batteries (connected in series)
Product info	Manufacturer: Landport Type: EV12-110
Output voltage	24 VDC
Battery capacity	110 Ah (approx. 10 hours)
Operating temperature	Discharge: -20 ... +60° C Charging: 0 ... +50° C Storage: -20 ... +60° C
Charger make	Manufacturer: S.P.E. Type: CBHF2 24-30
Connection charger	Plug-in connector with reverse polarity protection

6.1 Nameplate and manufacturer

Nameplate:

		R. Beck Maschinenbau GmbH Im Grund 23 D-72505 Krauchenwies ☎ +49(0)7576 962978-0 www.beck-maschinenbau.de	
<h1 style="margin: 0;">Mobillifter</h1>			
Baureihe line	line	Typ type	ML120
Maschinen-Nr. machine no.	machine no.	Baujahr year of construction	202
Bemessungsspannung U = nominal voltage U =	nominal voltage U =	Frequenz/Phasenzahl frequency/phases	24 V
Stromart kind of current	kind of current	Volllaststrom I = operating current I =	DC 60 A
Überstromschutz, extern excess current protection, external	excess current protection, external		63 A

Figure 2: Nameplate

Hersteller:

Reinhold Beck Maschinenbau GmbH Im Grund 23 72505 Krauchenwies (Germany) Phone: +49 (0) 7576 / 962 978 - 0 Fax: +49 (0) 7576 / 962 978 - 90 E-Mail: info@beck-maschinenbau.de
--

Note:

Before using the unit in a way that deviates from the described suitability (see section ⇒ 5.2), it is essential to consult the manufacturer. Otherwise all warranty, liability and other claims for damages of the operator against the manufacturer will be voided!

7 Dimensions

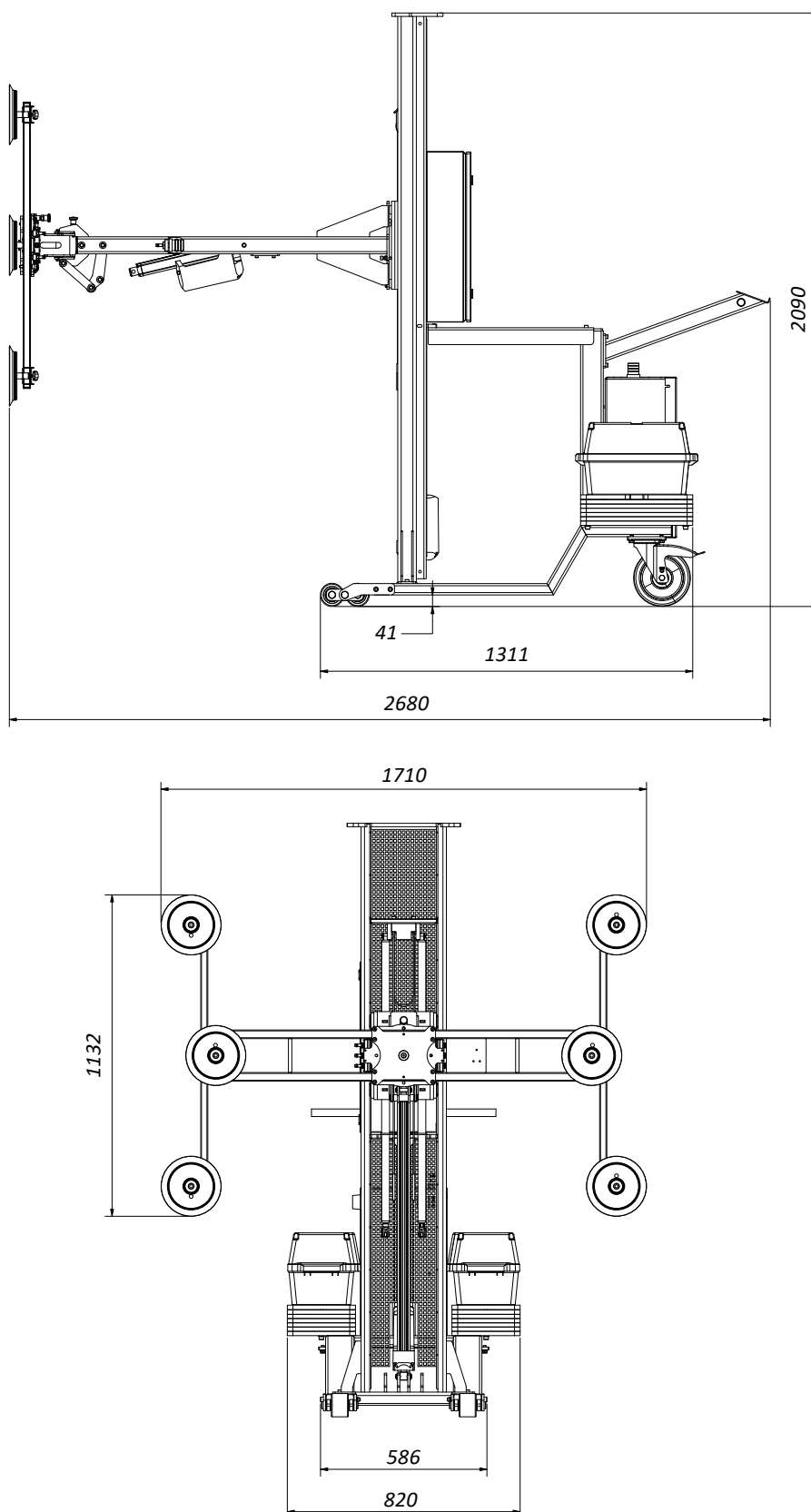

Figure 3: Dimensions ML-120







Subject to design and dimensional changes!

8 Transport to the installation site

Only trained personnel may be used for the following work:

- Transport the Mobile Lifter
- Unloading the Mobile Lifter
- Check delivery condition of the Mobile Lifter

8.1 Unloading the Mobile Lifter

	<p><i>There is an increased risk of accidents when unloading and transporting the Mobile Lifter! The Mobile Lifter can fall or tip over due to its weight!</i></p>
	<p><i>Use only suitable and technically perfect lifting gear and suspension systems with an adequate lifting capacity of 1000 kg. Transport the Mobile Lifter on level, solid ground!</i></p>
	<p><i>When placing the Mobile Lifter, pay attention to the possible danger of crushing in the area of stationary objects around the Mobile Lifter!</i></p>
	<p><i>Warning: Increased risk of injury and death! Never stand under the load when lifting and putting it down! Instruct bystanders to leave the danger zone!</i></p>
	<p><i>Warning: Increased risk of injury and death! Do not enter or climb onto the forklift platform during transport!</i></p>
	<p><i>Increased risk of crushing feet and toes! Wear steel-toed safety shoes!</i></p>

8.1.1 Unloading from the transport vehicle using a forklift truck

- With the forks set appropriately, drive centrally into the designated places on the freight pallet on the longitudinal side of the Mobile Lifter and lift carefully. Fork length of the forklift truck at least 1.20 m!
- Carefully lift the Mobile Lifter from the truck. The net weight of the Mobile Lifter is approx. 440 kg.

	<p><i>Danger to life when using a forklift truck! Keep a sufficient distance from the forklift truck and watch its speed. Vehicles with combustion engines also produce toxic exhaust gases. Wear a breathing mask if necessary.</i></p>
---	---

8.1.2 Unloading from the pallet using a forklift truck or crane



Figure 4: Transport eyelet

- Remove all fasteners required for transport that secure the Mobile Lifter to the pallet.
- Directly in front of the control cabinet is the transport eyelet (T), which are center of gravity balanced for lifting the Mobile Lifter with a transport rope.
- Feed a transport rope with sufficient load capacity for the approx. 440 kg Mobile Lifter through the transport eyelet (T) and attach the other side to a special load hook for forklift trucks or directly to a crane hook.
- Now lift the Mobile Lifter gently from the pallet and place it with the wheels on the floor.



Note: If the transport eyelet proves to be an obstacle when opening the control cabinet door, it can be removed in the meantime by loosening the nut on the underside.

8.1.3 Check delivery condition

Check for completeness and transport damage. In case of transport damage or missing parts, document these immediately on the consignment note of the transport company. At the same time, inform the manufacturer of the situation.

8.1.4 Unpacking and placing

Unpack the Mobile Lifter and remove the packing material. Lift the Mobile Lifter from the transport pallet with a forklift truck. When doing so, drive under the centre of the long side of the Mobile Lifter with appropriately adjusted forks and carefully lift slightly. Then lift carefully from the pallet, remove the pallet and set the Mobile Lifter down on the ground.

	<p>Fire hazard! Do not smoke or light an open fire.</p>
	<p>Dispose of the packaging material in an environmentally friendly manner!</p>

8.1.5 Transport to the installation site

After unpacking, the Mobile Lifter can be moved to the installation site either via its four swivel castors or using a suitable means of transport. If a forklift or lift truck is used for this purpose, the general safety regulations must be followed and observed.

8.2 Requirements for the installation site

The following guidelines apply with regard to space requirements, load-bearing capacity and the condition of the substrate:

- Space requirements: L x H x W = approx. 2700 x 2200 x 1750 mm
- Load capacity: Concrete of classification B 15
- Conditions: Level, smooth, non-slip and tilt-free

8.3 Temporary storage

If the Mobile Lifter is not put into operation immediately after delivery, it must be stored carefully in a protected place. Carefully cover the entire Mobile Lifter so that neither dust nor moisture can penetrate. **Note:** To prevent deep discharge, the two lead-acid batteries must be fully charged regularly (trickle charge min. 12.5 V).

8.3.1 Short term storage

- Dry environment
- Protect components at risk of corrosion
- Park in a stable place

8.3.2 Long term storage

- Dry environment
- Protect components at risk of corrosion
- Protect Mobile Lifter from dirt
- Park in a stable place

8.4 Lashing on a transport vehicle

For further transport, the Mobil Lifter must be securely fastened to a transport pallet (as shown in ⇒ Figure 5), which is then lashed to the loading area of the transport vehicle.. For this purpose, at least 2 lashing straps with the appropriate load-bearing capacity must be used, see (Z1) and (Z3) in ⇒ Figure 5.

The responsibility for safe loading is borne by the respective shipper!

	<ul style="list-style-type: none"> • <i>A <u>separate lashing strap</u> must be used for each lashing and must be tensioned individually on the floor of the loading area of the vehicle! The pallet must also be secured against slipping.</i> • <i>Important: <u>Only the pallet and the boards shown below may be lashed with the lashing straps, as the Mobile Lifter can be damaged if the lashing straps come into direct contact.</u></i>
---	--

It is imperative that the Mobile Lifter is secured to the pallet without lashing straps. To do this, proceed as follows:

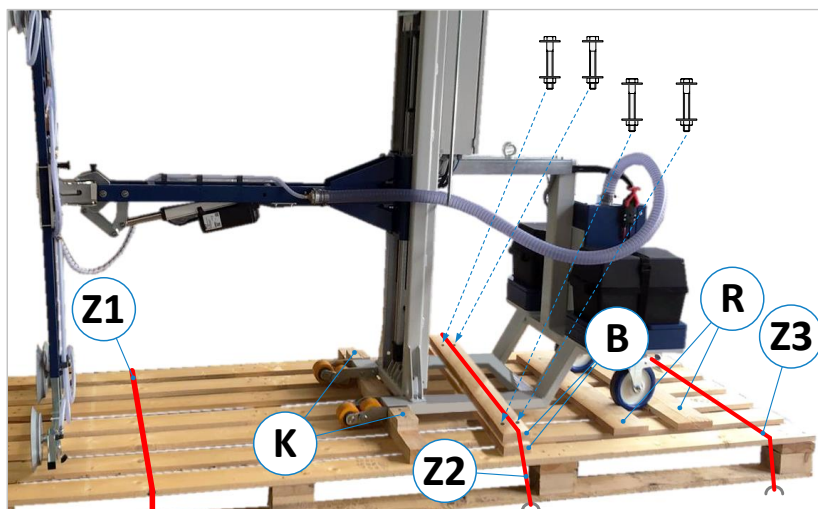

Figure 5: Securing the Mobile Lifter to the pallet

1. Place the Mobile Lifter centrally on the pallet and secure it with the parking brakes to prevent it from rolling away.
2. Secure the Mobile Lifter in the area between the front and rear rollers on the pallet
→ To do this, use e.g. two wooden boards (B). One of the boards serves as a support and the other as a base (base board thickness $\hat{=}$ height distance to pallet).

3. For fixing you need min. 4 hexagon bolts (at least M10) + 4 nuts + 8 large washers.
4. Then drill 4 through holes (e.g. \varnothing 10.5 mm each) through the boards (B) and the pallet base.
5. Screw the Mobile Lifter in place using the hexagonal bolts with suitable nuts and a large washer on both sides. Also make sure that the bolts are stable and sufficiently long.
6. The Mobile Lifter can be additionally lashed between the screws of the boards (B), see lashing strap (Z2).
7. Secure the rear swivel castors from rolling away with wooden boards (R) or wedges screwed into the pallet.
8. Secure the front fixed castors against lateral forces with 1 continuous underlay board + 2 wooden blocks (K).
9. The pallet must then be lashed down in the transport vehicle.
10. The transport eyelet shown in ⇒ Figure 4 serves exclusively to lift the Mobile Lifter and should expressly not be used for lashing.

Please note the following when lashing in the transport vehicle:

- The loading area of the transport vehicle must always be clean and dry.
- The lashing straps used must be suitable for the total of the freight is (approx. 440 kg + pallet weight).
- Moving and loose parts must be clamped, locked or separately secured for transport.
- Fastening on the loading area is done by lashing down: This means that the transport pallet is secured by frictional locking. The load is pressed so firmly onto the loading surface that it can no longer slip. The clamping tool should have a high STF value at the frictional connection, e.g. long-lever ratchets.
- In addition, anti-slip mats should be used to provide even more safety.
- The ideal lashing angle (α) for tie-down lashing is 83° to 90°. Therefore, the lashing straps should pull downwards approx. vertically. As the angle decreases, the pretensioning force of the lashing is reduced.
- If necessary, additionally secure the Mobile Lifter on the pallet against tipping over.
- Observe the permissible total weight of the transport vehicle.
- Ensure that the permissible axle loads of the transport vehicle are observed. The load must be distributed evenly on all axles of the vehicle.

9 Components and controls

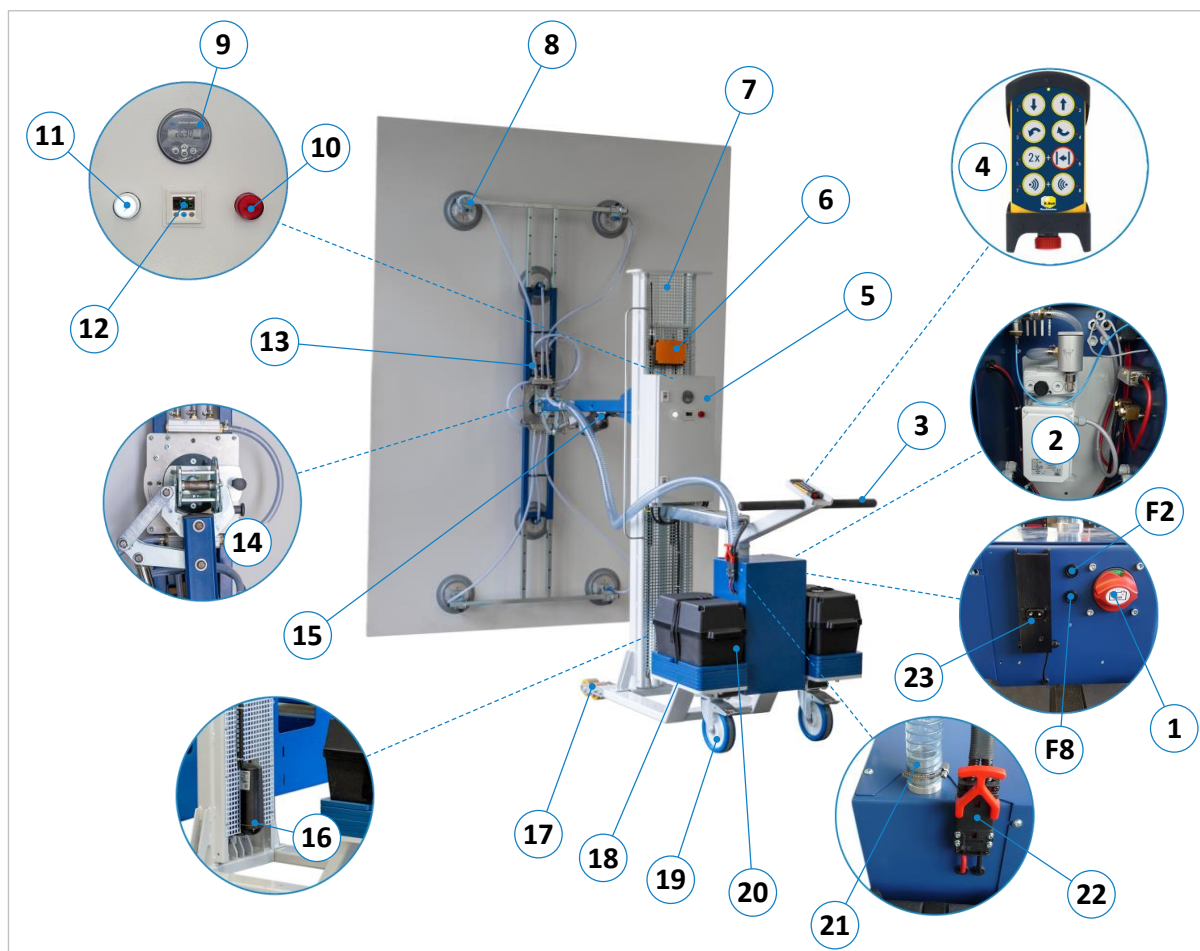

Figure 6: Components and controls ML-120

Pos.	Description	Pos.	Description
1	Main switch	14	Swivelling and rotating mechanism
2	Vacuum unit	15	Actuator for tilt adjustment
3	Handlebar	16	Actuator for height adjustment
4	Remote control with radio transmitter	17	Front castors (4 pieces)
5	Control cabinet	18	Balance weights
6	Radio receiver with high-flex antenna	19	Rear castors with brake (2 pieces)
7	Lifting mast with protective grille	20	Battery box (2 pieces)
8	Vacuum pad	21	Vacuum connection for main hose
9	Battery monitoring indicator	22	Battery box connection
10	Warning lamp "vacuum insufficient"	23	Charging station for remote control
11	Indicator lamp "ready for operation"	F2	Glass fuse (1 A slow) for battery monitor (9)
12	Digital pressure switch & indicator	F8	Glass fuse (1 A slow) for charging station (23)
13	Vacuum clamping device		



10 Installation and commissioning

The Mobile Lifter must be operated in such a way that no crushing or shearing points occur between the Mobile Lifter and/or the picked-up load and objects in the vicinity. Therefore, ensure sufficient space around the Mobile Lifter and make sure that there are no persons in the movement area (recommended safety distance at least 2 metres on all sides). It must always be possible to carry out all activities on the Mobile Lifter or the load without obstructions when operating it as intended.

The following installation and operating requirements must be observed:

- ⚠ The Mobile Lifter must be integrated into the existing machinery in such a way that the basic safety requirements of the EU Machinery Directive 2006/42/EC are met. This must be checked and ensured by the operator of the Mobile Lifter.
- ⚠ The environment must not be explosive.
- ⚠ For stationary use, both parking brakes on the rear castors must generally be activated.
- ⚠ This operating manual and any supplementary documents must be read carefully and understood. All safety instructions and regulations must be observed and complied.

11 Operating the Mobile Lifter

	Before operating the Mobile Lifter, the operating personnel must ensure that no hazards are caused by the mechanical movements of the Mobile Lifter or during mobile transport.
	Generally wear safety shoes with steel toecaps and suitable protective work clothing!

11.1 Switching ON the Mobile Lifter ML-120

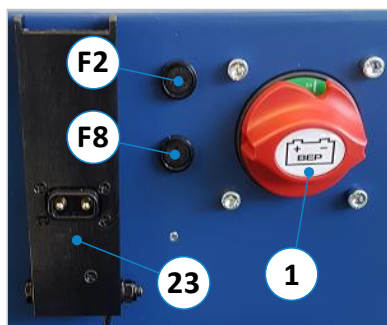





Figure 7: Main switch

- Before working with the Mobile Lifter, the batteries must be in a charged state (for details refer to section ⇨ 11.7).
- Before clamping, the vacuum must be completely built up.
- To switch on the entire system of the Mobile Lifter ML-120, turn the main switch (1) to the right to the “ON” position → After waiting for approx. 3 seconds, the white indicator lamp (11) on the control cabinet lights up and signals that the unit is ready for electrical operation. → The vacuum pump starts automatically.
- The fuse (F8) protects the charging station (23) and the fuse (F2) protects the battery monitor (see ⇨ Figure 15). I_{max} = each 1 A slow-blow.

- If the system is switched on for the first time or after a longer period of time, the red warning lamp (10) lights up until the vacuum required for safe operation is reached.
→ Work may only be started after the red warning lamp (10) is off.

	<i>Risk of injury from falling or crashing panel material! Work may only be started when the red warning lamp (10) is off! Only then is there sufficient vacuum for safe clamping of the panel by means of the vacuum clamping device.</i>
	<i>Please observe the operating and pause times of the actuators as specified by the manufacturer: Tilt Actuator: under full load max. 20 % operation at 80 % pause (related to the total time). Height Actuator: under full load max. 15 % operation at 85 % pause (related to the total time)</i>
	<i>After work or during maintenance work, the main switch (1) must generally be switched off.</i>

After completing the work, please observe and follow the supplementary instructions in section ⇨ 11.13.

11.2 Adjustment options

To ensure that the Mobile Lifter can be used as flexibly as possible in panel handling, it has various adjustment options, which are carried out either manually or by electric motor.

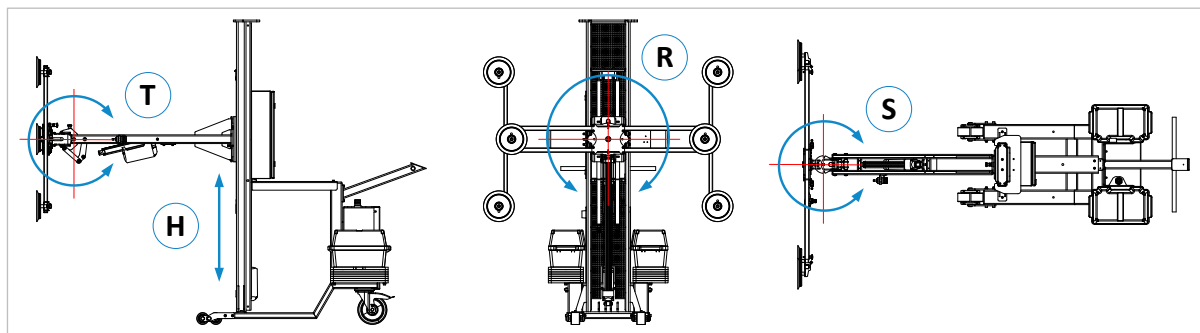



Figure 8: Adjustment options ML-120

Pos.	Designation	Description	Type of adjustment
H	Lifting height (vertical)	Height adjustment range	motorised, variable up to max. 1600 mm
T	Tilt (vertical)	Tilt range	motorised, variable -90° ... 0° ... +90°
R	Rotate (frontal)	Rotation range	manual 0° ... 270°, lockable in 90° steps
S	Swivel (horizontal)	Swivel range	manual -85° ... 0° ... +85°, lockable in steps



Risk of impact and crushing with all the above adjustment options!
Keep your hands out of the range of movement of the lift mast and vacuum clamping device.
Before any adjustment, make sure that no persons or body parts are in these areas.

11.3 Using the radio remote control

The radio remote control can be used to adjust the height and the tilt angle and to release the load from the vacuum pads of the Mobile Lifter.

11.3.1 Storage compartment and charging station



Figure 9: Storage compartment directly on the handlebar



Figure 10: Charging station next to the main switch

- The remote control should not be permanently stored in the charging station, as this can negatively affect the battery life.
- Therefore, place the remote control in the storage compartment on the push bar of the Mobile Lifter between work steps and during short interruptions.
- The batteries of the remote control can be recharged at any time in the charging station, as it is active even when the main switch is turned off.
- At the end of work, it is advisable to place the remote control in the charging station to the left of the main switch to recharge it and keep it ready for use the next day.

11.3.2 Remote control cunctions

 **Important:** Before establishing the radio connection for the remote control, the supplied high-flex antenna must be connected via BNC coupling to the receiver box (6) above the control cabinet. Also make sure that the battery of the remote control is in a fully charged condition.

Action / State	Procedure / Description
Switch on the remote control	To switch on, unlock the push button (N) by turning it to the left: → LEDs (L7) + (L8) are flashing → LED (L1) must be statically lit
Operating state	LED (LB) lights up green: → Radio connection is established → Remote control is ready for use LED (LB) flashes green: → Radio connection is interrupted, no operational readiness! LED (LB) lights up red (a 3-fold beep is also heard): → Battery empty or capacity ≤ 10 %
Establish radio connection	When LEDs (L7) + (L8) are flashing, press buttons (7) + (8) together: → A beep sounds while the buttons are pressed → As soon as the radio connection is established, LED (LB) lights up static green and LEDs (L7) + (L8) go out
Lifting or lowering the clamped load¹	→ Press button (1) or (2) until the desired position is reached.
Tilting the load forwards or back¹	→ Press button (3) or (4) until the desired tilt angle is reached
Release the clamped load	For safety reasons, this procedure is carried out via a time-controlled 2-button switching sequence → Press button (5) <u>twice within one second</u> and press button (6) <u>once within another second</u> . → <u>The load is released immediately!</u>
	 <i>Risk of injury when releasing! Keep hands, body parts or persons under the load area away while pressing the buttons (5) + (6)!</i>
Switching off after work	→ Press push button (N) to switch off and lock the remote control
Charge battery	The charging station for the remote control battery is permanently active, even if the main switch is switched off. This means that charging is possible at any time.
Emergency stop function	The push button (N) is also used to stop the drives immediately in case of emergency. The power supply to the vacuum unit is maintained to prevent a plate from falling.
Restart after switching off via main switch or push-button (N)	If the remote control is to be put back into operation after being switched off via the main switch (⇒ Figure 7) or push button (N), the radio connection must be re-established. When switching on, the LEDs (L7) + (L8) flash and the LED (L1) next to the button (1) must light up statically. If another LED next to another button lights up instead, the radio connection cannot be established. → Then press the button next to the lit LED once and then press button (1).



Figure 11: Radio remote control

¹ **Note:** The height and tilt adjustment can be carried out simultaneously.

11.4 Lifting and tilting the clamping platform

The height and tilt adjustment is motorised via the respective buttons of the remote control (refer to section ⇒ 11.3.2). The force is transmitted via two actuators, one for the lift mast and one for the tilting axis.



Before the clamping platform is lifted, the Mobile Lifter must first be fixed in place by the two lockable brakes on the two rear castors.



Be aware of the risk of crushing, especially when lowering. When lowering, keep hands, feet and other body parts out of the area between the load and the parking surface. Also make sure that there are no persons in the danger zone.

11.5 Rotating and swivelling the clamping platform

To rotate or swivel the clamping platform, first activate the two rear wheel brakes. For adjustment, the corresponding locking bolt (R) or (S) must be unlocked by pulling it out (see ⇒ Figure 13).

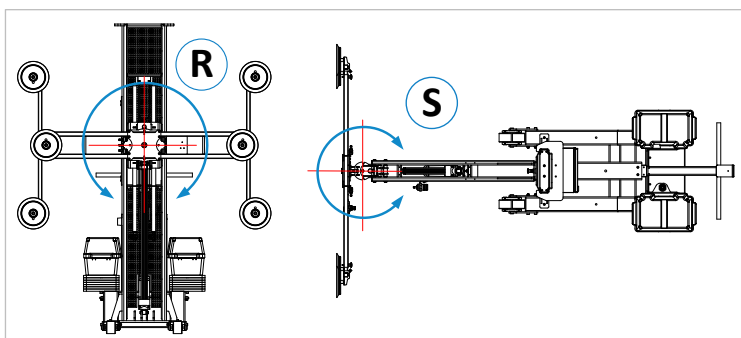

Figure 12: Rotation and tilt adjustment

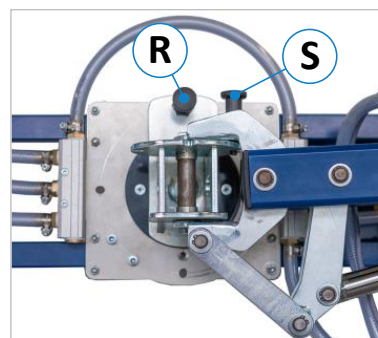

Figure 13: Locking bolts

- To rotate around the axis (R), pull the locking bolt (R) and rotate the clamping platform by 90°, 180° or 270° to the desired position → Let the locking bolt (R) engage there.
- To swivel around the axis (S), pull the locking bolt (S) and swivel the clamping platform to the desired position -85°, 0° or +85° → Let the locking bolt (S) engage there.

11.6 Moving the Mobile Lifter via castors



Before moving the Mobile Lifter with a clamped load, ensure that all six vacuum pads are working correctly, that the red warning lamp (10) is off and that the panel material is securely clamped so that the load cannot fall off during movement.



Figure 14: Swivel castors and handlebar

The Mobile Lifter can be moved with or without a clamped load. Please note that the view to the front is considerably restricted by a clamped panel. Furthermore, the moving area must not be blocked by obstacles or objects.

- Before moving, release the two parking brakes (B) on the castors (19) at the rear of the Mobile Lifter.



For movements with a clamped load, the load must be lowered as far as possible (floor-free) in order to keep the falling distance of a detached panel as short as possible.

- Now move and steer the Mobile Lifter to the desired location using the handlebar (3).



Risk of impact and crushing as well as the risk of persons being run over during movements with the Mobile Lifter. Due to the restricted view to the front, make sure that there are no persons or obstacles in the travel area. If necessary, have a second person instruct you.

- After the movement or during stationary work on the Mobile Lifter, the two brakes must be activated again.

11.7 Battery monitoring

The battery monitor unit built into the control cabinet door is used to indicate and monitor the battery status of the two lead-acid batteries that are used to supply power to the Mobile Lifter.



Figure 15: Battery monitor unit

- With the two buttons (+) and (-) you can switch between the following display modes:
 - Charge status in percent (%)
 - Battery voltage (V)
 - Estimated operating time in hours (h)
- The unit emits an acoustic warning beep as soon as the batteries need to be recharged (for charging procedure see ⇒ 12.3).
- To save the batteries, the unit has an integrated deep discharge protection, which switches off the power for the Mobile Lifter as soon as the battery voltage falls below a critical value.
- **Remark:** The unit has already been set correctly at the factory. Therefore, do not make any changes to the settings.

11.8 Vacuum clamping device with pressure switch

With the vacuum clamping device, panels to be transported can be fixed quickly and safely.

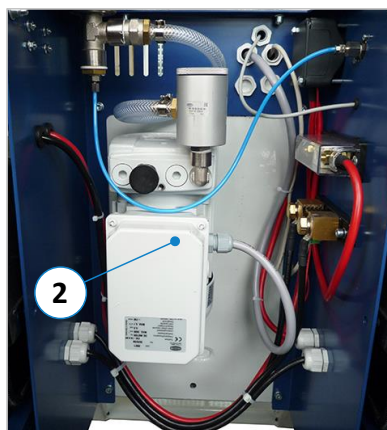

Figure 16: Vacuum unit

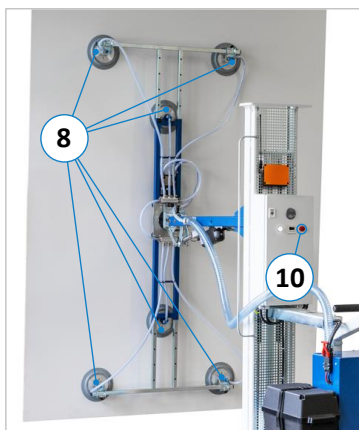

Figure 17: Vacuum pads

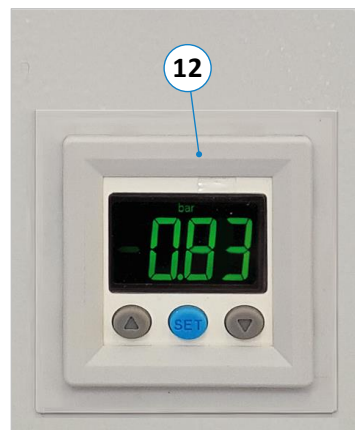



Figure 18: Digital pressure switch

- The heart of the system is the vacuum unit (2) shown in ⇒ Figure 16, including the electric vacuum pump. These components are located in the blue housing between the two batteries.
- The six vacuum pads (8) shown in ⇒ Figure 17 are used to fix the panel material to be clamped. The outer four vacuum pads (8) can be manually adjusted to the size of the panel to be clamped. The detailed procedure for adjustment can be found in the section ⇒ 11.12.
- The digital pressure switch (12) shown in ⇒ Figure 18 controls the vacuum pump and indicates the current operating vacuum (between 0.3 and 0.9 bar). If the vacuum falls below 0.25 bar, the red warning lamp (10) lights up until the digital pressure switch has restored the operating vacuum. **Remark:** Do not change the settings of the digital pressure switch, it has already been optimally adapted to the system at the factory.

	<ul style="list-style-type: none"> • The vacuum pump must not be operated with the housing cover open or on a wet or damp surface. There is a risk of short-circuit with increased risk of electric shock! • Maintenance and repair work on the vacuum pump may only be carried out by authorised electricians in accordance with the electrical regulations. • In the event of a power failure and/or failure of the vacuum pump, there is a risk of a falling load. Therefore, generally wear safety shoes!
	<p>The ingress of liquids (e.g. coolants or lubricants) can damage the vacuum pump and reduce the adhesion of the plate. If necessary, connect a liquid separator between the pump and the clamping device and always ensure that the vacuum pads are firmly seated.</p>

11.9 Requirements for clamping panels

- ☞ **No** panel material may be clamped via the vacuum clamping device if the red warning lamp (10) on the control cabinet lights up (insufficient vacuum).
- ☞ Panel material that cannot be held securely by the vacuum suction pads because the surface is too rough, porous or permeable to air (e.g. MDF panels) must not be clamped, lifted or transported with the Mobile Lifter. The vacuum pump is not suitable for the above mentioned surfaces!



Increased risk of injury when clamping, lifting and transporting unsuitable material!

- ☞ To avoid non-uniform load distribution, a panel to be clamped should always be aligned as centrally as possible to the 6 vacuum pads before it is clamped via vacuum. Details on optimal load distribution can be found in ⇒ Figure 1 in the section ⇒ 11.12.

11.10 Clamping panel material



Caution! Danger of crushing hands and fingers between the vacuum pad and the panel to be clamped. Do not reach into this danger area and wear protective gloves if necessary.



Danger of cutting and abrasion from sharp-edged plates. Be careful with sharp-edged plates and wear protective gloves if necessary..



Risk of injury from falling panel material! Work may only be started when the red warning lamp (10) is off! Only then is there sufficient vacuum for safe clamping of the panel by means of the vacuum clamping device.

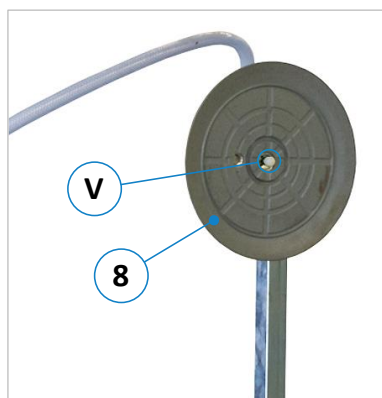

Figure 19: Vacuum pad clamping side

- Before clamping, thoroughly clean the contact surfaces of the six vacuum pads (8) as well as the surface of the plate to be clamped from chips, dust and dirt. Only then is an optimal adhesive surface guaranteed and no dirt is sucked into the pump. The contact surfaces of the vacuum pads and the plate must also be dry.
- Each of the six vacuum pads (8) is equipped with a sensing valve (V) which triggers and switches on the vacuum by contact with the panel.
- Position the six vacuum pads slowly and simultaneously against the panel surface → The vacuum is only triggered after the valves (V) have been pressed inwards by the plate approx. 2 - 3 mm.



The ingress of chips, dust, dirt and liquids can damage or destroy the vacuum pump!

- **Important:** Make absolutely sure that all vacuum pads are firmly and securely seated before lifting the panel or moving it to another location. Make absolutely sure that all vacuum pads are firmly and securely seated before lifting the panel or moving it to another location. The red warning lamp must be off!



Dirty, wet and damp contact surfaces or vacuum pads that are not firmly adhered to the plate lead to a reduction of the operating vacuum → The red warning lamp lights up.

11.11 Loosen a clamped panel

- Position the plate with the surface or edge to be set down as close as possible to the parking surface on which the plate is to be placed or set down (e.g. machine table top or workshop floor).
- Before loosening a clamped plate, any dirt, chips, dust etc. around the vacuum pads must be removed (still under operating vacuum) so that nothing of it gets into the inside of the pump. We recommend using an industrial Hoover for this purpose.
- Then press button (5) on the remote control twice within 1 second and press button (6) once within the next second to release the plate.



Danger of crushing when setting resp. putting down! The panel falls down immediately! Keep hands, body parts and persons out of the danger zone between the panel and the parking surface!

11.12 Adjusting the vacuum pad positions

In order to adapt the clamping surfaces to the size of a panel and to optimally adjust the load distribution, the four outer of the six vacuum pads can be moved in their positions. In addition, the distance between the two vacuum pad support rails can be adjusted by means of a hole grid.

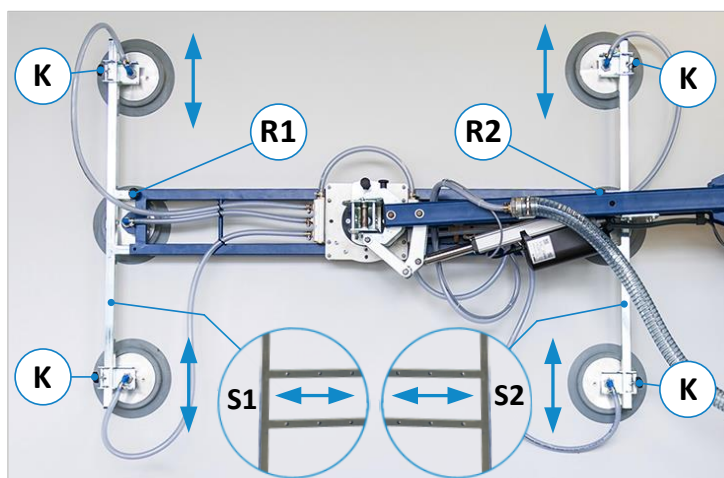

Figure 20: Adjusting the vacuum pad positions

- Open the clamping handles (K) to move the outer four vacuum pads in the directions of the arrows.
- By pulling the locking bolt (R1), the mounting rail (S1) can be adjusted in the hole grid of 100 mm in the direction of the arrow shown.
- By pulling the locking bolt (R2), the mounting rail (S2) can be adjusted in the hole grid of 100 mm in the direction of the arrow shown.
- Adjust the vacuum pads in such a way that an optimal load distribution is ensured (see ⇒ Figure 1).

- After adjustment, retighten all clamping handles and engage the locking bolts in position.

11.13 Measures after operation



When the Mobile Lifter has finished operating, any panel material that has been clamped on must be released from the vacuum and removed. Then turn the main switch to the "OFF" position .

- After switching off the main switch (1), clean all contact surfaces of the vacuum pads.
- After parking the Mobile Lifter, both parking brakes of the rear castors must be tightened.
- If necessary, recharge the supply batteries with the battery charger (for details, see section ⇒ 12.3) and place the radio remote control in the charging station to charge it (see section ⇒ 11.3.1).

Remark: Charging operation is also possible with the main switch turned off.



The Mobile Lifter should not be used while the battery unit is charging .

In addition, the Mobile Lifter must be secured against unauthorised use by one of the following means:

- Lock the Mobile Lifter away or park it in such a way that unauthorised persons cannot access it.
- Secure the Mobile Lifter with a lock chain or wire rope to prevent unauthorised movement.
- Store the radio remote control in a safe place or lock it away.
- Attach a prohibition sign to the Mobile Lifter to prevent unauthorised use.
- Remove the main switch handle (see next section ⇒ 11.13.1).

11.13.1 Pulling off the main switch handle

To prevent unauthorised use of the Mobile Lifter, the rotary handle of the main switch (1) can be pulled off. The procedure is as follows:

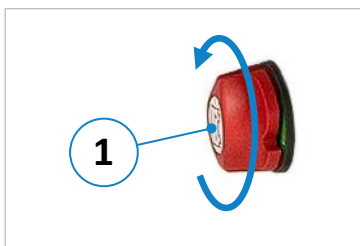

Figure 21: Securing the main switch

- Turn the main switch handle counterclockwise ↺ to the "OFF" position (see ⇒ Figure 21).
- Then turn the main switch handle again by approx. 45° in the same direction ↺ (against a slight resistance).
- Then the main switch handle can be removed to the front.

To replace the main switch handle, the previous procedure is carried out in reverse. After the coded attachment, the main switch handle must be pressed against the housing before it is turned to the right ↻.

12 Battery charger CBHF2 24-30

12.1 General information and warnings

- The electronic charger with microprocessor is suitable for the battery types installed in the Mobile Lifter.
- The charging process is fully automatic and electronically controlled. The unit has integrated protection against overload and short circuits as well as reverse polarity protection for the terminals.
- The charging plug (L) of the battery charger has mechanical reverse polarity protection.
- Never disconnect the battery during charging as this may cause sparks.
- Never use the unit in a rainy environment, in wet, damp rooms or in high humidity.
- Before starting the charging process, check that the unit corresponds to the battery voltage, that the charging current is set according to the battery capacity and that the selected charging curve (for lead-acid and hermetic gel batteries) is correct for the type of battery to be charged.
- Also check that the input voltage of the charger, whose data is given on the name plate, corresponds to the charging voltage.
- If necessary, replace the built-in fuse with one of the same type and current rating (see name plate). To replace the fuse, remove the top cover of the unit. The fuse holder is located underneath on the left-hand side.
- Only use the charger in a well-ventilated environment.
- Follow the battery manufacturer's instruction.

12.2 Operating and display elements



Figure 22: Battery charger

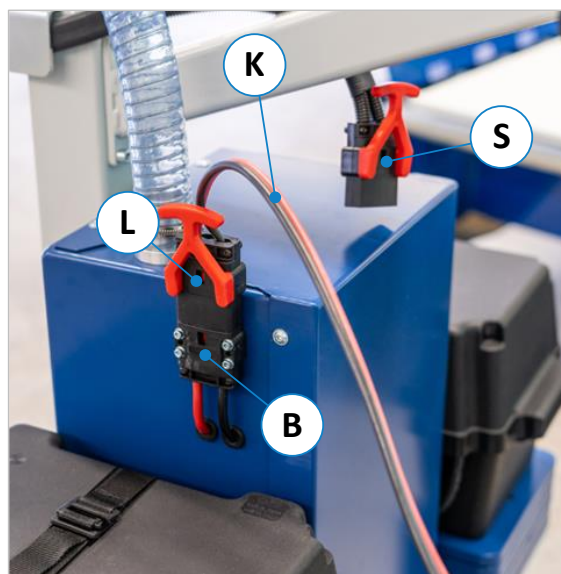

Figure 23: Charging cable in the plugged-in state

- Three-digit LED display incl. symbol (1) to indicate A = charging current, U = battery voltage, h = charging time, C = charging ampere hours [Ah], E = consumed energy [kWh].
- Push-button for selecting the display mode (2): A, U, h, C, E.
After approx. 10 seconds, the display always jumps back to the charging current.
- Red control LED (3) lights up → The charging cycle has started.
- Yellow control LED (4) lights up → The final phase of the charging cycle is in progress.
- Green control LED (5) lights up → The charging cycle is finished.

(S) System plug for connecting the Mobile Lifter to the batteries for power supply.

(B) Output socket to which the 24 VDC battery voltage is connected to power the system.

(L) Charging plug of the charging cable (K) for connection for the charging process.

12.3 Charging the battery unit

- Disconnect the system plug (**S**) of the Mobile Lifter from the battery unit (**B**).
- Plug the earthed plug of the charger into a 230 VAC socket.
- Insert the charging plug (**L**) into the battery unit (**B**) of the Mobile Lifter.
- After that, the display of the battery charger alternately indicates various information about the internal program of the charger: After the display “**SPE**”, the software version installed in the unit is shown and then the following parameters in sequence: Battery voltage, charging current, number of charging curve and finally the message “**GEL**” or “**Acd**”, depending on whether the charging curve entered corresponds to hermetic GEL batteries (“**GEL**”) or lead acid batteries (“**Acd**”).
- **Check whether the type shown in the display corresponds to the battery type**
 → The display must indicate “**Acd**”, as two lead-acid batteries are installed in the ML-120 Mobile Lifter (If the display indicates “**GEL**”, there is an error and the unit must not be used!).
- At this point, an internal test is carried out on the battery voltage to decide whether the charging process can be started or not.
- If the battery is not properly connected to the charger, the message “**bat**” appears in the display. This message also appears in case of a negative test result (e.g. reversed polarity or incorrect connection to the battery). If the test is positive, the display indicates the battery voltage value for about five seconds and the charging process starts.
- The progress of the charging cycle is indicated by three control LEDs red (**3**), yellow (**4**) and green (**5**). At the end of charging, when the LED (**5**) is green, disconnect the supply cable of the charger from the socket and from the battery unit (**B**) of the Mobile Lifter.
- Reconnect the system plug (**S**) of the Mobile Lifter to the battery unit (**B**).
- Work can now be started or continued.

12.4 Possible faults

Fault	Check / remedy
The charger does not switch on.	Check that the mains cable is plugged into the socket and that the internal fuse has tripped.
Charging cycle does not start and bat is indicated	Check battery connection and polarity.
The yellow LED (4) does not light up even after 15 hours of charging time and the display shows E03 .	Check battery for external damage and components.
E01 appears in the display.	The maximum permitted battery voltage has been exceeded. Charging is interrupted.
On chargers with a thermal protection switch, the message E02 is indicated	The maximum permitted temperature has been exceeded. Charging is interrupted.
E03 appears in the display.	The maximum permissible duration for the charging time has been exceeded. Charging is interrupted.
Sct appears in the display.	The protection timer has interrupted charging.
Srt appears in the display.	The maximum duration for the charging time has been exceeded. Possible internal short circuit.

12.5 Additional notes on lead-acid batteries

The lead-acid batteries used in the Mobile Lifter are maintenance-free (no refilling required).

⚠ Caution! The gases emitted during charging are explosive. Do not smoke in the immediate vicinity of the batteries. Avoid naked flames and sparks when working with cables and electrical equipment.

⚠ Caution! The acid contained in the battery is corrosive. In case of contact with the acid from the battery, rinse the affected area with tap water and consult a doctor immediately. Always wear protective goggles and gloves when working on the batteries.

13 Troubleshooting

Repair and maintenance work may only be carried out by competent, trained and instructed personnel.

	<i>Repair work on electrical, mechanical and pneumatic components may only be carried out by authorised and trained specialist personnel.</i>
---	--

Proceed systematically when searching for the cause of a malfunction. If you are unable to find the fault or to remedy the malfunction, contact our customer service department (phone: 0049 7576 / 962 978 - 0).

Before you call us, please follow these steps:



- Make a note of the information on the nameplate of your Mobile Lifter (see ⇒ Figure 2).
- Keep these operating instructions and any supplementary documents at hand.

The more precisely you describe the fault to us, the better we can then remedy the situation.

Fault	Possible Cause	Remedy
The Mobile Lifter cannot be adjusted by motor	Batteries of the battery unit are empty	→ Charge the batteries (see ⇒ 12.3)
	Batteries of the battery unit defective	→ Contact customer service
	Remote control batteries empty	→ Charge batteries (see ⇒ 11.3.1)
	Linear actuator defective	→ Contact customer service
	Remote control defective	→ Contact customer service
The batteries of the battery unit cannot be recharged	Charger does not work resp. reports malfunction	→ For details see section ⇒ 12.4
	One or both batteries defective / deep discharged	→ Contact customer service
	Charger / charging cable / charging plug defective	→ Contact customer service
Remote control cannot be charged	Lower glass fuse (F8) has tripped	→ Check/replace fuse (⇒ Figure 7)
	Charging station contacts are dirty	→ Clean contacts (see ⇒ 14.5)
	Charging station for remote control is defective	→ Contact customer service
Battery monitor does not work	Upper glass fuse (F2) has tripped	→ Check/replace fuse (⇒ Figure 7)
	Battery monitoring indicator is defective	→ Contact customer service
Plate does not stick to the vacuum pads	Panel surface is too rough	→ Only clamp smooth surfaces
	Panel surface or vacuum pad dirty	→ Clean contact surfaces
	Vacuum pad or sensing valve defective	→ Replace defective parts
	Too little vacuum (red warning lamp lights up)	→ Wait until the red lamp goes out
	Vacuum pump defective	→ Contact customer service
	Vacuum connection/hose leaking	→ Check all connections
No vacuum is created	Vacuum hose kinked	→ Check / re-route hoses
	Vacuum unit or component defective	→ Contact customer service
	Digital pressure switch or component defective	→ Contact customer service

14 Maintenance and repair

Maintenance and repair work may only be carried out by competent, trained and instructed personnel. If necessary, further operating instructions and/or additional documents must be observed.

  	<p>After maintenance or repair work on the Mobile Lifter, always carry out a function test.</p> <ul style="list-style-type: none"> • Switch off the main switch before carrying out any maintenance or repair work. • WARNING: When opening the battery boxes, there is an acute risk of electric shock at the pole terminals and other cables, even when the main switch is switched off! • Wear safety shoes. • Wear suitable protective clothing.
---	--

	<p>Maintenance and repair work on electrical, pneumatic and mechanical components may only be carried out by <u>authorised and trained personnel</u>.</p>
---	--

	<p>Before any maintenance and repair work is carried out, chapter ⇨ 5 "Safety" must be read carefully and observed!</p>
---	--

14.1 General maintenance intervals

Interval	Activity
Daily	Remove coarse dirt. Check all components for damage and have them replaced by qualified personnel if necessary. Customer service (phone: 0049 7576 / 962 978 - 0).
Monthly	Slightly lubricate castors, pallet truck rollers, clamping lever threads and bearing points.
Annual	Check the wire rope for visible damage (cracks, fraying, etc.). If there is any damage, stop the mobile lifter and contact the customer service.
Every 1.5 years	For safe operation, the Mobile Lifter must be inspected. Please contact our customer service for this (phone: 0049 7576 / 962 978 - 0).

14.2 Check mechanical equipment

- Regularly check all screw connections and whether all wheels are correctly fastened.
- If necessary, retighten loose screw connections with a suitable spanner.
- Regularly check the function and ease of movement of the clamping levers and locking pins.
- Regularly check that there are no breaks or cracks in weld seams.

14.3 Check electrical equipment

- Regularly check the functions of the electrical equipment.
- Regularly check that there are no loose or pinched cables.
- Have damaged cables repaired by competent electrical personnel.
- The two supply batteries are maintenance-free. Therefore, no checking or refilling of water is necessary. The batteries only need to be kept dry and clean.
- Only use original spare parts when replacing them! Otherwise the warranty claim will be invalidated.

14.4 Check pneumatic equipment

- Regularly check all hoses, connections and fittings for defects and leaks.
- Regularly check all hoses for proper and trip-free routing as well as kinks.
- Regularly check the proper functioning of the valves on the vacuum pads.

14.5 Maintenance of the charging contacts for the remote control

- Clean the contacts of the radio remote control and the charging station at regular intervals (depending on the stress and environment), e.g. with some steel wool or fine sandpaper.
- Afterwards, we recommend wetting the contacts with a little contact spray.

14.6 Maintenance of the vacuum pump

For optimum function and suction performance, the vacuum pump should be maintained at regular intervals. The maintenance intervals depend on the respective use and the ambient conditions.

	<p><i>First have the vacuum pump disconnected from the power supply by a qualified electrician. Work on the pump must be carried out by a mechanically trained specialist.</i></p>
---	---

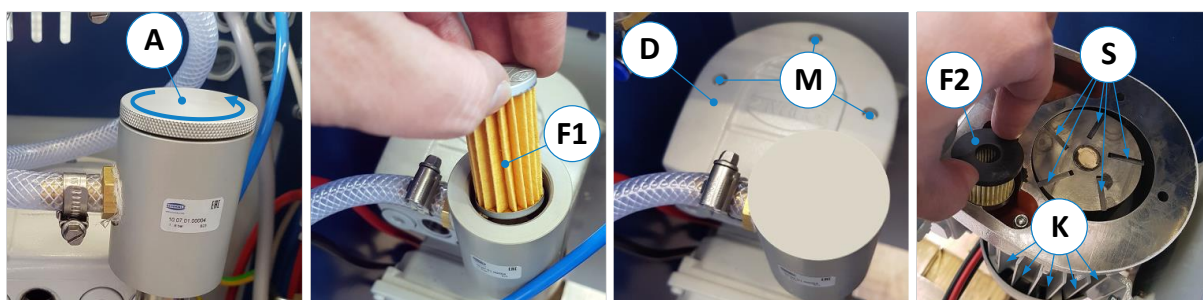

Figure 24: Vacuum pump with filter inserts and carbon sliders

1. To make the vacuum pump accessible, open the blue housing of the vacuum unit (2) shown in ⇒ Figure 6 by unscrewing the housing screws and removing the housing cover.
2. Begin by checking the outer filter insert and clean it if it is clogged with dust. To do this, unscrew the cover cap (A), pull out the filter (F1) and blow through from the inside to the outside with compressed air (do not wash out) → However, if the filter is clogged, oily or greasy, it must be replaced with a new original spare part.
3. Then screw the cover cap (A) back on.
4. Blow out any dirt in cooling air ducts (K) carefully with compressed air.
5. Then remove the pump housing cover (D) by loosening the screws (M) to check the five carbon sliders (S) and the inner filter insert (F2).
6. The carbon sliders (S) are subject to wear due to abrasion on the housing. Check the width of the sliders with a caliper gauge after 3,000 operating hours at the latest or at least once a year.
→ The width of the sliders must be at least 12.5 mm. If not, contact customer service.
→ If sliders need to be replaced, simultaneously blow out the housing with dry compressed air.
7. Afterwards, pull out the inner filter (F2) and check it as well. If there is dust, clean it with compressed air (as described in step 1. above) → However, if the filter is clogged, oily or greasy, it must be replaced with a new original spare part.
8. Finally, close the cover (D) again and secure it with the screws (M).
9. **Remark:** The roller bearings integrated in the pump are maintenance-free and lubricated for life. Defective bearings may only be replaced with original parts from the manufacturer.

15 Decommissioning

- For decommissioning, the supply batteries must be disconnected by a qualified electrician.
- Avoid deep discharge of the two lead-acid batteries. If the Mobile Lifter is only to be taken out of service temporarily or stored for a longer period, the batteries must be fully charged before storage and at regular intervals. The trickle charge level of a battery is 12.5 V. If the voltage drops below this value, a recharge is recommended.
- For recommissioning, observe chapter ⇒ 10 “Installation and commissioning”.
- For the final scrapping of the Mobile Lifter, please refer to chapter ⇒ 16.

16 Disassembly and scrapping

When dismantling and scrapping the Mobile Lifter, the current EU regulations or the respective regulations and laws of the country of operation, which are prescribed for proper dismantling and disposal, must be observed. The aim is to dismantle the Mobile Lifter and its various materials and components properly, to recycle all possible parts and to dispose of non-recyclable components in the most environmentally friendly way.

	<p>Please pay particular attention to</p> <ul style="list-style-type: none"> • <i>the dismantling of the Mobile Lifter in the working area</i> • <i>proper dismantling of the Mobile Lifter and accessories</i> • <i>a safe and proper removal of the Mobile Lifter</i> • <i>proper separation of all components and materials.</i>
---	--

When dismantling and disposing the Mobile Lifter, the laws and regulations in force at the place of use concerning health and environmental protection must be observed.

	<p>Remove all residues of oil, grease and other lubricants and have them disposed of properly by a qualified disposal company.</p>
---	---

When separating, disposing of or recycling the Mobile Lifter materials, comply with the environmental protection laws in force at the place of use regarding the disposal of industrial solid waste toxic and hazardous waste.

	<ul style="list-style-type: none"> • <i>Hoses and plastic parts as well as other components that are not made of metal must be dismantled and recycled or disposed of separately.</i> • <i>Electrical components such as cables, switches, connectors, transformers, etc. must be removed and (if possible) recycled or otherwise disposed of in a qualified manner.</i> • <i>Pneumatic and hydraulic parts such as valves, solenoid valves, pressure regulators, etc. must be removed and (if possible) recycled or otherwise disposed of in a qualified manner.</i> • <i>Dismantle the base frame and all metal parts of the Mobile Lifter and sort them according to material type. Metals can be melted down and recycled.</i>
--	--

	<p>The lead-acid batteries installed in the Mobile Lifter contain environmentally hazardous substances and must therefore be recycled by a specialised recycling company.</p>
---	--

In the event of improper disposal of lubricants, the following residual risks to the environment and health exist:

	<p>Pollution of the environment by seepage into groundwater or sewage system.</p>
---	--

	<p>Poisoning of the personnel contracted for the disposal.</p>
---	---

Note: The disposal of lubricants considered toxic and hazardous must be carried out in accordance with the regulations and laws in force at the respective place of use. Only qualified disposal companies that have the appropriate permits for the disposal of used oil and lubricants are to be commissioned with the disposal.

17 Spare parts

17.1 General

Only original spare parts from the manufacturer or the external manufacturers of installed additional components may be used. Otherwise, any warranty claims will be invalidated.

17.2 Recommended spare parts

We have a full range of spare parts for the lifting equipment in stock. However, it may be advisable for some customers to have certain spare parts in their own stock. We will be happy to make suggestions for suitable stocking, with regard to the current operating conditions.

17.3 Return of parts

Please do not return any parts that are worn out by normal use, defective or damaged by accidents.

Only damaged or unused parts that are obviously covered by the warranty should be returned. Return such parts to us immediately so that your warranty claim does not expire beforehand.

When returning parts, please provide the following data from the name plate (see ⇨ Figure 2):

- Model
- Serial number
- Year of manufacture

Please do not forget to include the name, address and telephone number of the person in charge.

17.4 Ordering spare parts

To order spare parts, enter the following data from the name plate (see ⇨ Figure 2):

- Model
- Serial number
- Year of manufacture

On request, we will also be pleased to send you a spare parts list for your Mobile Lifter.

To do this, simply send us a short e-mail with the subject "Request for a spare parts list" and the above-mentioned details from the name plate to info@beck-maschinenbau.de or alternatively fill out our online contact form on <https://beck-maschinenbau.com/en/contact/>.



EU - Declaration of Conformity

in accordance with the EU Machinery Directive 2006/42/EC Annex II

The manufacturer,

Fa. Reinhold Beck
Maschinenbau GmbH
Im Grund 23
DE-72505 Krauchenwies (Germany)
Phone: 0049 - 7576 962 978 0
Fax: 0049 - 7576 962 978 90

hereby declares that the manufactured machine

Model: **Mobile Lifter ML-120**
Type designation: Lifter / Industrial Truck
Serial number(s):
Year of manufacture:

in the version provided complies with the EU Machinery Directive 2006/42/EC and the following further directives:

The following harmonised standards and instructions have been applied in manufacturing the machine:

- **EN ISO 12100:2010** Safety of machinery - General principles for design - Risk assessment and risk reduction

Furthermore, the following other standards and technical specifications were applied:

- **DIN EN ISO 3691-5** Industrial trucks - Safety requirements and verification - Part 5: Pedestrian propelled trucks

Name: Beck
First name: Reinhold
Position: Managing Director

Krauchenwies, 15/04/2024

Place and date



Signature